

Operating manual

Original operating manual



SENTA PUR L

Combination bathing lift

Version 2.5/English

Subject to technical modifications

2019-04-08

Table of contents

1	Imprint	5
1.1	Acknowledgement	5
1.2	Manufacturer's address	5
1.3	TÜV quality seal	5
2	Introduction.....	6
2.1	Preface	6
2.2	Liability and warranty	6
3	Operating manual.....	7
3.1	Validity	7
3.2	Type plate.....	7
3.3	Description.....	7
4	Safety	8
4.1	Intended and appropriate use.....	8
4.2	Other prescriptions	8
4.3	Safety instructions	8
4.4	List of used safety instructions.....	9
4.5	Warnings	10
5	Transport.....	12
5.1	Unpacking the product.....	12
5.1.1	Removing the cardboard.....	12
5.1.2	Loosening the product from the pallet.....	13
6	Installation	14
6.1	Electrical connection.....	14
6.2	Electric motor/battery unit.....	14
7	Operating elements and their function.....	15
7.1	Handset	16
7.1.1	Handset functions	17
7.2	The control unit.....	17
7.2.1	Control unit.....	17
7.2.2	Control unit, North-American version	18
7.2.3	Explanation of the LED-indications	18
7.3	24V battery unit	19
7.4	External charging unit/wall charger.....	19
7.5	Manual emergency lowering system	20
7.6	Electrical emergency lowering system.....	21

7.7	Emergency stop switch.....	22
7.8	Crash protection	22
8	Operation.....	23
8.1	Prior to use	23
8.2	Using the SENTA PUR L as sitting lift	23
8.3	Using the SENTA PUR L as stretcher lift.....	24
8.4	Function of the safety armrests	24
8.4.1	Assembly/disassembly of the safety armrests	25
8.5	Disassembly/assembly of the adjustable wings.....	25
8.5.1	Disassembly of the wings.....	26
8.5.2	Assembly of the wings	26
8.6	Disassembly/assembly of the side rails	26
8.6.1	Disassembly of the side rails.....	27
8.7	The armrest (option)	29
8.7.1	Assembly/disassembly of the armrests	29
8.8	Operating the SENTA PUR L	30
8.9	Lifting the patient from a bed	31
8.9.1	Getting autonomously onto the seat lift.....	32
8.10	Transferring a patient into a bath tub.....	33
8.11	SENTA PUR with digital scale SL (option)	34
8.11.1	Safety instructions digital scale SL	35
8.11.2	Cleaning the scale	35
8.11.3	Using the scale	35
8.11.4	Zeroing and Taring	35
8.11.5	Replacing the Batteries.....	36
8.12	SENTA PUR with calibrated scale (option)	36
8.12.1	Calibrated application	36
8.12.2	Homologations and approvals	36
8.12.3	Product features	36
8.12.4	Embedded functions:	37
8.12.5	Environmental conditions:.....	37
8.12.6	Electrical safety.....	37
8.12.7	Cleaning	37
8.12.8	Field of application.....	37
8.12.9	Waste disposal	37
8.12.10	Operating the Scale	38

8.12.11	“Stable Error” error message	39
8.12.12	LIVE WT	39
8.12.13	Error message in operation.....	40
8.12.14	Error message in setup mode.....	41
8.12.15	Diagnostic error messages	42
8.12.16	Charging the battery of the calibrated patient scale:.....	43
9	Cleaning/disinfection	44
9.1	Cleaning the SENTA PUR L bathing lift.....	44
9.2	Disinfecting the SENTA PUR L bathing lift	44
9.3	Sterilising the SENTA PUR L bathing lift	44
10	Checks/tests	45
10.1	Maintenance of the 24 Volt battery	45
11	Waste disposal	46
11.1	Disposal of the packaging material.....	46
11.2	Disposal of the product.....	46
12	Troubleshooting/After-sales service.....	47
12.1	Troubleshooting help.....	47
13	Assembly/disassembly.....	49
13.1	Handset.....	49
13.2	Rear castor replacement	49
13.3	Front castor replacement	50
13.4	Mounting plate for control incl. magnet.....	51
13.5	Replacing the battery	52
14	Appendix.....	53
14.1	Technical data	53
14.2	Dimensions of the SENTA PUR L	54
14.3	Declaration of conformity.....	55
14.4	Spare parts and accessories of the SENTA PUR L.....	56
14.5	Electromagnetic Compatibility	57
14.6	Journal	61

1 Imprint

1.1 Acknowledgement

Dear customer, we would like to express our sincere thanks for the trust you have placed in us by purchasing this BEKA Hospitec GmbH product. Our products are manufactured and tested according to stringent quality criteria.

1.2 Manufacturer's address

	<p>BEKA Hospitec GmbH Am Rübenmorgen 3 35582 Wetzlar Phone: +49(0)641-9 22 22-0 Fax: +49(0)641-9 22-22-20 info@beka-hospitec.de</p>
---	--

1.3 TÜV quality seal

	<p>BEKA Hospitec GmbH is certified by TÜV SÜD Product Service GmbH to DIN EN ISO 13485 in the current issue. Therefore, the development, manufacturing, quality assurance and service of our entire product range is subject to high quality standards.</p>
---	---

2 Introduction

2.1 Preface

A correct use of the device is imperatively in order to ensure its proper and safe functioning. Please read the provided operating manual carefully and observe in particular the therein contained safety instructions.

The maintenance, inspection, assembly and installation as well as well as further technical interventions on the product must only be executed by BEKA Hospitec either by specialised companies authorised to this effect by BEKA Hospitec. The product may only be operated by trained staff.

Spare parts may only be replaced by authorised staff as described in paragraph 13 of this operating manual.

2.2 Liability and warranty

- On the basis of the information contained in this manual, the publisher accepts no liability for damages resulting from improper, incorrect or inappropriate use of the product. The product must only be operated by persons, who are familiar with the manual and the product as well as the national regulations, laws and prescriptions related to work, safety and accident prevention.
- The manufacturer of the product is only responsible for the safety and the reliability of the product, if regular functional tests and checks are conducted. Operate the product only with original accessories, otherwise the manufacturer's liability will expire.
- In case of technical interventions, such as extensions and fittings to our products, which are not carried out by BEKA Hospitec either by a specialist company authorised by BEKA Hospitec, all warranty rights on the modifications as well as on the device or on the device function, which are related to the modification, shall expire.
- For damages resulting from the use of spare parts and accessories, which are not authorized by the manufacturer, any further liability of the manufacturer shall be excluded.
- Please note that there might be minor differences between the images and explanations contained in this manual and the actually supplied device. Subject to technical modifications and error.
- The SENTA PUR L product is equipped with "B"-Type applied parts. All exposed, touchable, conductive parts are thereby considered as applied part.

3 Operating manual

3.1 Validity

This operating manual contains information, which is required for the operation and use of the product. In addition to the description of the equipment, the operating manual also includes a number of abstractions and exemplary illustrations. The equipment of the product therefore may differ in part from the descriptions and illustrations. Furthermore, please observe also the manuals with regard to the cleaning and the disinfection as well as the assembly and the disassembly of individual components of the product.

Please read the operating manual and the safety instructions before starting to use the product. Keep the operating manual near the device for future reference.

3.2 Type plate

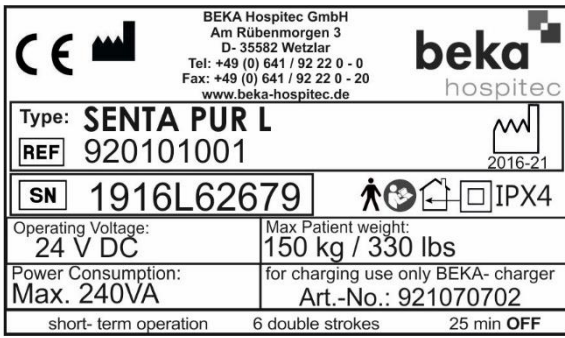
		<p>This image shows the type plate. The type plate is located on the chassis of the combination bathing lift. The shown serial number (SN) 1916L62679 is only for exemplifying. In case of queries, please mention the serial number printed on the type plate of your device.</p> <p><i>Note: Because of legal regulations, it might be required that the article number and the serial number should be computer-readable as well and therefore they might be printed on the type plate in the form of a bar code as well.</i></p>
--	--	--

3.3 Description

In the operating manual, the product is called SENTA PUR L, SENTA, combination bathing lift, bathing lift or lift. These designations all refer to the same device.

4 Safety

4.1 Intended and appropriate use

The SENTA PUR L product has been designed for lifting and transferring patients in hospitals, nursing homes and care centres. The product provides support during the bathing process.

The patient can be lifted from standing either reclined position. The SENTA PUR L combination bathing lift is to be used exclusively for the indoor transport of residents on smooth and level floorings.

The product may only be used for the specified purpose.

CAUTION



The product must be used by adequately qualified nursing staff with good knowledge of the care environment, its standard practices and usual procedures as well as in accordance with the directives included in the operating manual.
In case of doubt, please consult with the treating doctor.

4.2 Other prescriptions

The product meets the current VDE-prescriptions 0100 and 0100-710. However, have a specialist company check the compliance of your electrical installation with the applicable prescriptions prior to operating and using the product. This requirement is only applicable for Germany. In other countries, other requirements might be applicable. Ask a qualified electrician to install the wall charging unit in accordance with the regulations applicable in your country.

4.3 Safety instructions

Please read the following safety instructions prior to using the product. All notes, specifications and warnings mentioned on the device as well as in the present operating manual must be imperatively respected and observed. The manufacturer BEKA Hospitec shall not accept any liability for any damages, failures or faults caused by improper operation or handling.

4.4 List of used safety instructions



Please observe the accompanying documents/operating manual.



Warning Hazardous Area.



Applied part "Type B" to DIN EN 60601-1.



Special waste, no household waste.
The device and the packaging materials never must be disposed of in the domestic waste stream.



CE-label in accordance with the EC-Directive on Medical Devices.



Solely intended for indoor use.



Protection class II.

IPX4

Protection against the penetration of solids and liquids

4.5 Warnings

Note

- The product may only be used and operated by trained staff.
- Protect the product against direct sunlight and heat.
- The equipment is not authorised for use in potentially explosive atmospheres.
- Never exceed the duty cycle or the maximum load.
- Make sure that the battery is charged in a well-ventilated room.
- The product must not be operated during the charging process of the battery.
- Never cover up, over sticker or change the slots and holes of the device.
- The SENTA PUR L combination bathing lift is exclusively fit for indoor use.
- Please make sure that the patient firmly holds the safety armrests.
- Please make sure that the patient/resident is not hurt by the door frame when passing through doors.
- Please note that the extremities of the wings of the stretcher lift must **not** be used as seat!

Warning

- As soon as the patient/resident sits on the Senta lift, the safety belt must be attached and the safety armrests must be folded into position so as to surround and enclose the patient.
- Please make sure that your feet are not located in the area of the castors neither in the patient's/resident's area before and during the height adjustment.
- Please make sure that no one grabs in the hazardous areas (bracket, carrier frame) during the adjustment procedure. *Risk of crushing.*
- Please make sure that the patient/resident cannot tilt forward or sideward when he/she is being lifted.
- Please check that the hair, the arms and the legs of the patient are close to the body and cannot be squeezed.
- Please make sure that the patient/resident is correctly positioned onto the combination bathing lift and that the safety belt is applied.
- The battery and the control unit must not be exposed to permanent water jets.
- Please make sure that nothing is located in the direction of movement of the arm/hand rest when setting up the combination bathing lift (risk of injury).
- Please make sure that the legs and feet area of the patient/resident as well as those of the caretaker are free of obstacles (risk of injury).

Caution

- In case of unusual noises, damages or malfunctions, the product no longer must be used.
- Check prior to each use that all visible parts are intact. The product must not be used if any parts are damaged. Prior to each use of the device and its accessories, the user must check their functional safety and good condition (visual check, functioning).
- The product must be cleaned and disinfected after each use.
- Avoid slippery surfaces and thresholds.
- Do not move the SENTA PUR L combination bathing lift over sloping or uneven floors.
- Supervision of the caregiver is required throughout the treatment.
- Check prior to each lifting operation whether the help of a second assistant is required.
- Each lifting and transport operation must be adequately planned in order to ensure an optimal protection for the patient/resident.
- Do not position yourself between the combination lift and an obstacle during the transport operation.
- Do not lift the patient/resident higher than necessary.
- Engage the parking brakes of the wheelchair's castors to ensure a safe lifting and positioning of the patient/resident. Leave the product's brakes engaged (activated).
- Keep the transport of the patient/resident as short as possible and never leave the patient/resident unattended.
- Operate the product only with original accessories.
- Repairs to components of the SENTA PUR L combination bathing lift are to be carried out only by trained expert personnel. Please contact the after-sales service. The opening the device or other accessories will lead to the expiration of all guarantee, warranty and liability claims.

WARNING:



Any unauthorized repairs, reconstructions and modifications/alterations are not permitted for safety reasons and shall exclude all liability of the manufacturer for the resulting damages.

For damages resulting from the use of spare parts or accessories, which are not authorized by the manufacturer, any further liability of the manufacturer shall be excluded.

5 Transport

5.1 Unpacking the product

To remove the packaging materials, you will need a cutter knife.

NOTE



Take care not to damage the lift with the tools.

5.1.1 Removing the cardboard

Proceed in the following way to remove the cardboard:

- Cut the strap with the cutter knife.
- Remove the strap.

Note: *Do not cut in the cardboard, as this could damage the surface of the combination bathing lift!*



- Lift the cardboard up to remove it and put it aside

5.1.2 Loosening the product from the pallet

Both sides of the lift are strapped to the pallet.

Proceed in the following way to loosen the product from the pallet:

- Unscrew the fixing screws of the straps
- Remove the straps
- Release the brakes of the wheels



Brakes



After all fixations have been removed, you can remove the combination bathing lift from the pallet.

Remove the bubble wrap and the stretch film. Please take care not to damage the surface of the lift with the tools.

Your lift accessories are included in the supplied cardboard box.

6 Installation

The SENTA PUR L combination bathing lift is supplied ready for use.

6.1 Electrical connection

The SENTA PUR L combination bathing lift is equipped with a 24V-battery system. A VDE 0100 and 0100-710 compliant power connection is required for the wall charging unit.

In operation, the combination bathing lift is mains-independent.

6.2 Electric motor/battery unit

The SENTA PUR L combination bathing lift is equipped with a 24V-battery system. This motor is self-locking and therefore protected against unintentional lowering of the seat in case of malfunction or failure. The battery of the combination bathing lift must be completely charged prior to the first use of the device.

Please check that the emergency stop switch is released (unlatched). To unlatch, turn the emergency stop switch clockwise until it releases.

<p>NOTE</p> 	<p>The battery must be completely charged prior to the first use. The charging time is approx. 4 hours.</p> <p>Please check that the emergency stop switch is released prior to moving the seat.</p>
--	--

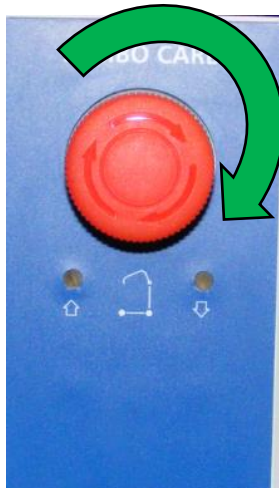

The emergency stop switch is released by turning the button to the right (i.e. clockwise).

7 Operating elements and their function

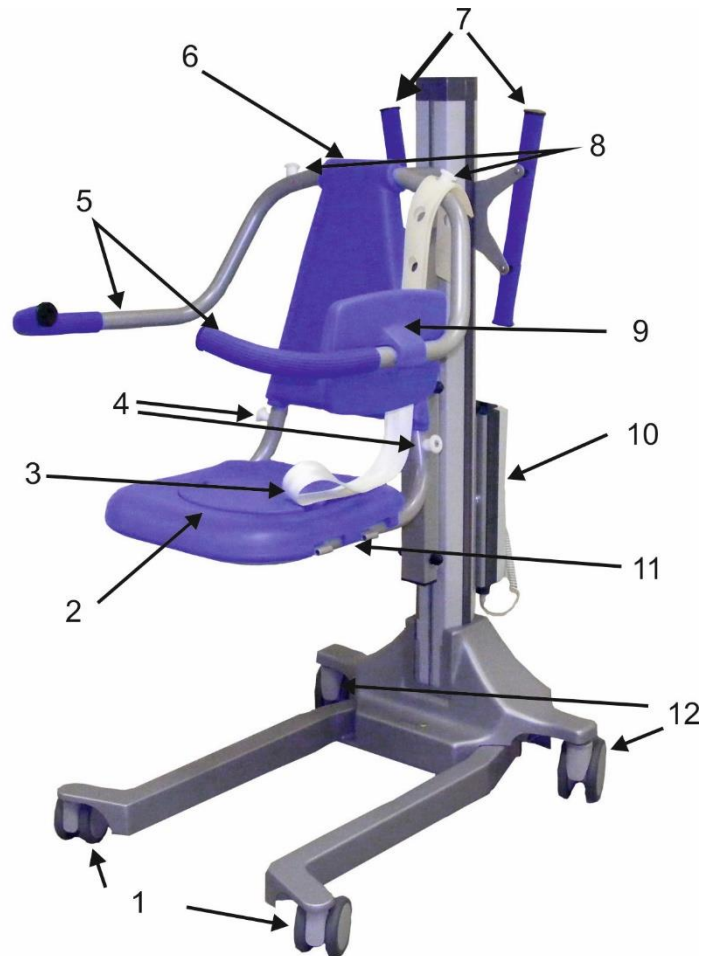

N°	Description	N°	Description
1	Front castors	7	Grab handles
2	Hygiene opening with cover	8	Belt holder
3	Belt	9	Removable backrest
4	Belt holder	10	Battery with control unit
5	Foldable safety armrests	11	Opening for adjustable stretcher lift wings
6	Seat	12	Rear castors, lockable



N°	Description
1	Footrest (optional)
2	Side rails (optional)
3	Adjustable stretcher lift wings (optional)
4	Removable backrest as headrest



CAUTION: The extremities of the wings (n° 3) must not be used as seat!

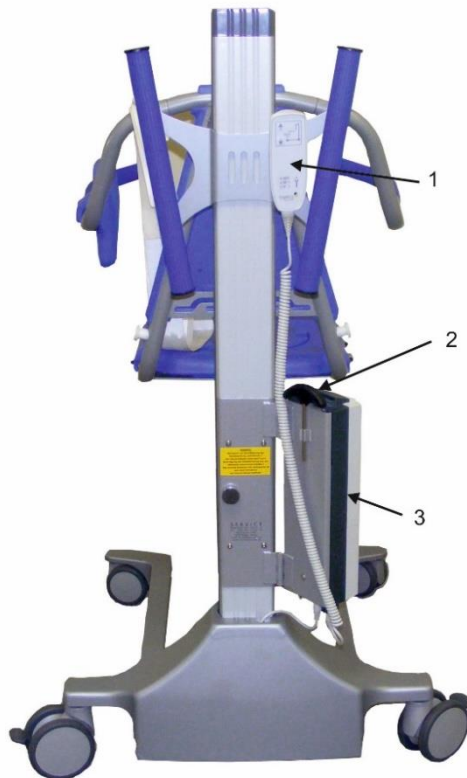

N°	Description
1	Handset
2	Allen wrench for the manual emergency lowering
3	Control box and battery, moveable

7.1 Handset



N°	Description	N°	Description
1	Seat/stretchers up	4	Service indication
2	Overload	5	Battery charge level indication

3	Seat/stretcher down		
---	---------------------	--	--

7.1.1 Handset functions

Battery and charge status indication (n° 5)

- If the *green* LED is illuminated, the battery is full (100%-50%). No charging required.
- If the *yellow* LED is illuminated, the battery must be charged (50%-25%)
- If the *red* LED is illuminated, the battery must be charged (less than 25%). When you push a button, an audible signal will be emitted.

Service indication (n° 4)

- If the orange LED of the service display flashes, you must request a check of your bathing lift.

Overload (n° 2)

- If the orange LED of the overload flashes, the maximum weight is exceeded.

7.2 The control unit

7.2.1 Control unit



N°	Description	N°	Description
1	Emergency stop switch	4	Lifting motor connection
2	Electrical emergency lowering system (buttons for use in case of handset malfunction)	5	Not used, sealed with caps
3	Handset connection		

7.2.2 Control unit, North-American version



N°	Description	N°	Description
1	Emergency stop switch	4	Lifting motor connection
2	Electrical emergency lowering system (buttons for use in case of handset malfunction)	5	Not used, sealed with caps
3	Handset connection	6	Charger cable connection

7.2.3 Explanation of the LED-indications



Green LED

The LED is on when the control unit is supplied with voltage through the power cable.



Yellow LED

The LED is on when the battery is charging.

NOTE



The battery can only be charged if the emergency stop switch is not actuated!

7.3 24V battery unit

The SENTA PUR L combination bathing lift is equipped with a 24V-battery system. Proceed as described in chapter 13.5 to remove the battery.



7.4 External charging unit/wall charger

The external charging unit (wall charging unit) is a switch-mode charger and is supplied ready assembled (on a mounting rail). It can be installed on any suitable wall. The required power cable is included in the delivery. The charging time for the battery units is approx. 4 hours.



N°	Description	N°	Description
1	Mains operation indicator	3	Charging indicator
2	Cable holder (optionally)		

Display function of the charging unit

- If the green LED (ON) is illuminated, the control unit is supplied with voltage through the mains cable.
- If the yellow LED (CHARGE) is illuminated, the battery is being charged.

7.5 Manual emergency lowering system

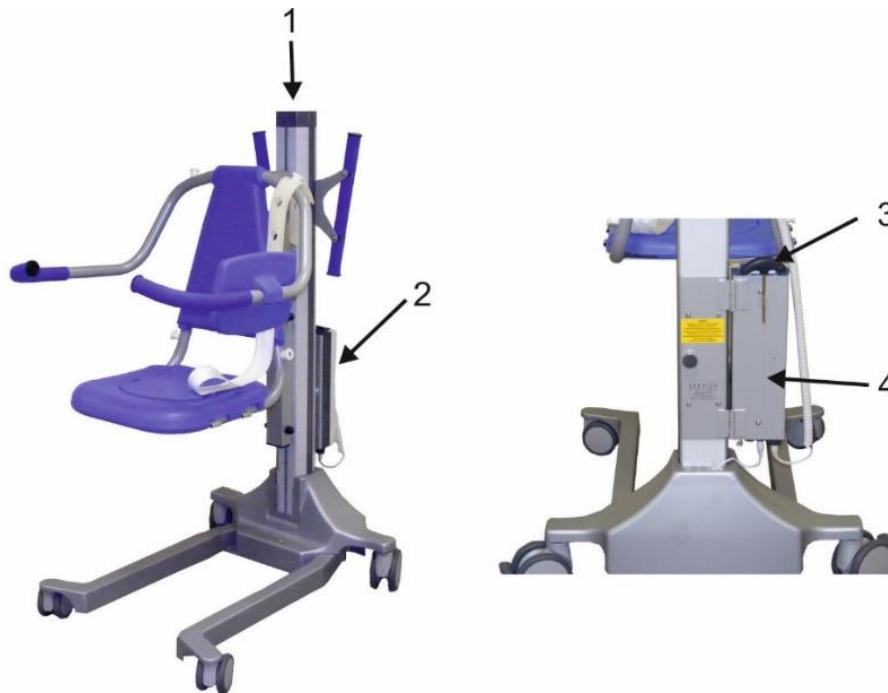

N°	Description	N°	Description
1	Manual Emergency Lowering System	3	Allen wrench
2	Battery	4	Battery compartment folded down

Activating the emergency lowering system:

The SENTA PUR L combination bathing lift is equipped with a manual emergency lowering system. Through the hole located in the end cap of the carrier frame, the seat or the stretcher can be manually lowered using the 6 mm Allen wrench, which is included in delivery. The emergency lowering system must only be used in case of emergency. The battery must be removed prior to use

CAUTION:



In order to avoid injuries due to the unintentional electrical movement of the spindle, please remove the battery prior to using the manual lowering system.

1. Remove the battery.
2. Fold the battery compartment to the side and take the Allen wrench.
3. Insert the Allen wrench through the hole in the end cap located on the spindle and turn it. If the seat raises, turn in the other direction.
4. Remove the Allen wrench after the emergency lowering is completed and put it back in the storage space provided to that effect.

NOTE:



The emergency lowering mechanism must not be treated with oil, grease or any other lubricant!
In case of a failure of the emergency lowering, please contact your service partner or the manufacturer.

7.6 Electrical emergency lowering system

Control unit button

Should your handset be defective or present a malfunction and provided that the battery still has sufficient voltage, you can raise or lower the seat by means of the buttons located on the control unit.

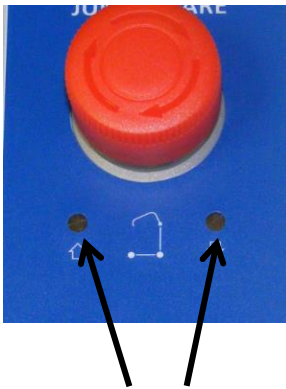

Insert a ballpoint or a similar object into the holes to actuate the buttons. The seat is raised or lowered.

Note: The buttons of the North-American version of the control unit are accessible without ballpoint.



Control unit button (North America)

7.7 Emergency stop switch

When the emergency stop switch is pressed, the electrical motor is immediately disconnected from the power supply. The motor stops immediately. The emergency stop switch should be used only in case of immediate danger to the resident or the caregivers.

The emergency stop switch can also be used to reduce discharging of the battery in case of intermediate storage.

By pressing the emergency stop switch, you can lock the SENTA PUR L combination bathing lift, thus making any unauthorized use of the device more difficult.

Turn the button in the direction of the arrow to unlock.

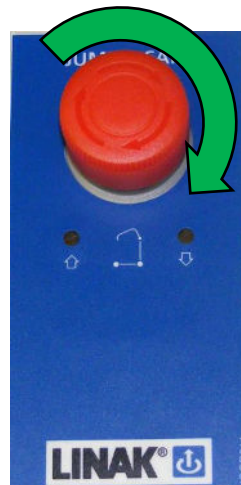

NOTE:



In the “North-American” version of the control unit, the battery can only be charged when the emergency stop switch is not actuated!

7.8 Crash protection

The SENTA PUR L combination bathing lift is equipped with an automatic protection device against collision. If the product encounters an obstacle during the lowering procedure, the electric motor is automatically switched off. In this case, raise the lift and remove the obstacle. After that, you can use the lift as usual.

8 Operation

CAUTION:

Please make sure that the patient/resident is always correctly positioned on the lift and that the safety belt is correctly attached and fastened.
Please make sure as well that the swivel arms are folded down during the transfer.

CAUTION:

To avoid any fall of the patient/resident, the lift must always be positioned in the bottommost position prior to the transfer.

8.1 Prior to use

Conduct the following check once a day, however at least prior to each use of the bathing lift, in order to ensure a safe and trouble-free operation:

- Visual check of the lift system (external damages and wear-and-tear).
- Check that no screws of the safety armrests are missing or loose.
- Check the functioning of the safety armrests.
- Perform a functional check of the handset.
- Test the electrical emergency lowering system
- Check the battery charging function.
- Check whether the castors run free.

8.2 Using the SENTA PUR L as sitting lift

The SENTA PUR L (sitting lift) is equipped with adjustable safety armrests, which offer the patient a safe grip. The safety armrests can be simply folded backward or forward. The special, easy-to-clean paddings offer the patient optimal hold. For the seat lift, an optional bedpan support is available.

This bedpan support cannot be used in combination with the stretcher lift wings!



8.3 Using the SENTA PUR L as stretcher lift

The SENTA stretcher lift is divided into three parts, so that the lift can be positioned on the desired side of the patient's bed. As soon as the lift is positioned at the patient's bed, both wings (left-hand side and right-hand side) are folded up or down, so that the patient's back and legs can be smoothly positioned onto the stretcher. The sides of the bed surface are formed so that the patient can be smoothly be lifted from and into the bed.

**CAUTION:**

Do not sit on the extremities of the wings!

Please note that the wing extremities must not be used as seat!

8.4 Function of the safety armrests

Both safety armrests can be folded back or completely removed independently from one another. To fold the safety armrests back, you have to turn them backwards in end position as shown on the image (8.4.1).

8.4.1 Assembly/disassembly of the safety armrests

To remove a safety armrest, turn it until both red markings on the safety armrest and its opening are opposite of each other (see image). Now, you can remove the safety armrest by pulling.

The safety armrest is re-assembled in reversed order.



Markings

NOTE:



The safety armrests must not be used to support the patient when standing up from the lift.

8.5 Disassembly/assembly of the adjustable wings

The SENTA PUR L combination bathing lift can optionally be equipped with adjustable wings.

These wings can be assembled or disassembled individually.

8.5.1 Disassembly of the wings

1. Engage the parking brakes.
2. Lift the wing to be disassembled up until the locking bars situated on the backside are in central position.
3. Pull the locking bars backwards and remove the locking bars from the frame.
4. Lift the wing further up until you can reach the interlock.
5. Turn the interlock 1/4 of a turn to the left or to the right, so that the locking bolt latches and the hinges are released.
6. Slide the wing in the direction of the carrier frame and remove the wing.
7. Disengage the parking brakes.



1 & 2

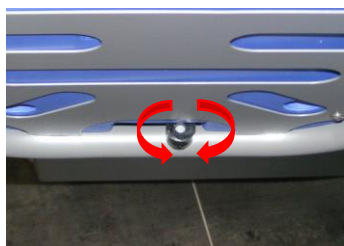

3 & 4



5

8.5.2 Assembly of the wings

1. Engage the parking brakes.
2. Turn the interlock 1/4 of a turn to the left or to the right, so that the locking bolt latches in the rear position.
3. Slide the wing to be assembled in the guide rails
4. Turn the interlock 1/4 of a turn to the left or to the right, so that the locking bolt latches in the front position, thus protecting the wing against slipping out.
5. Lift the wing up until you can hang the locking bars in the middle position of the frame.
6. Have the wing latched into the desired position.
7. Disengage the parking brakes.



1 & 3

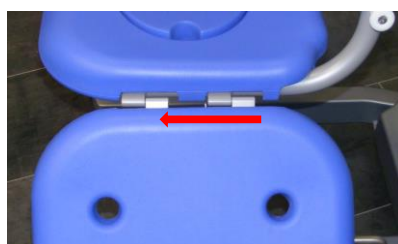

2



4 & 5

NOTE:



Please check that the locking bolt is correctly latched and that the wing cannot be inadvertently slid from the bolts.

8.6 Disassembly/assembly of the side rails

The SENTA PUR L combination bathing lift can optionally be equipped with side rails.



NOTE:



The side rail must be ordered directly ex-works.
Integrating a side rail after delivery is not possible!

8.6.1 Disassembly of the side rails

1. Open the lock

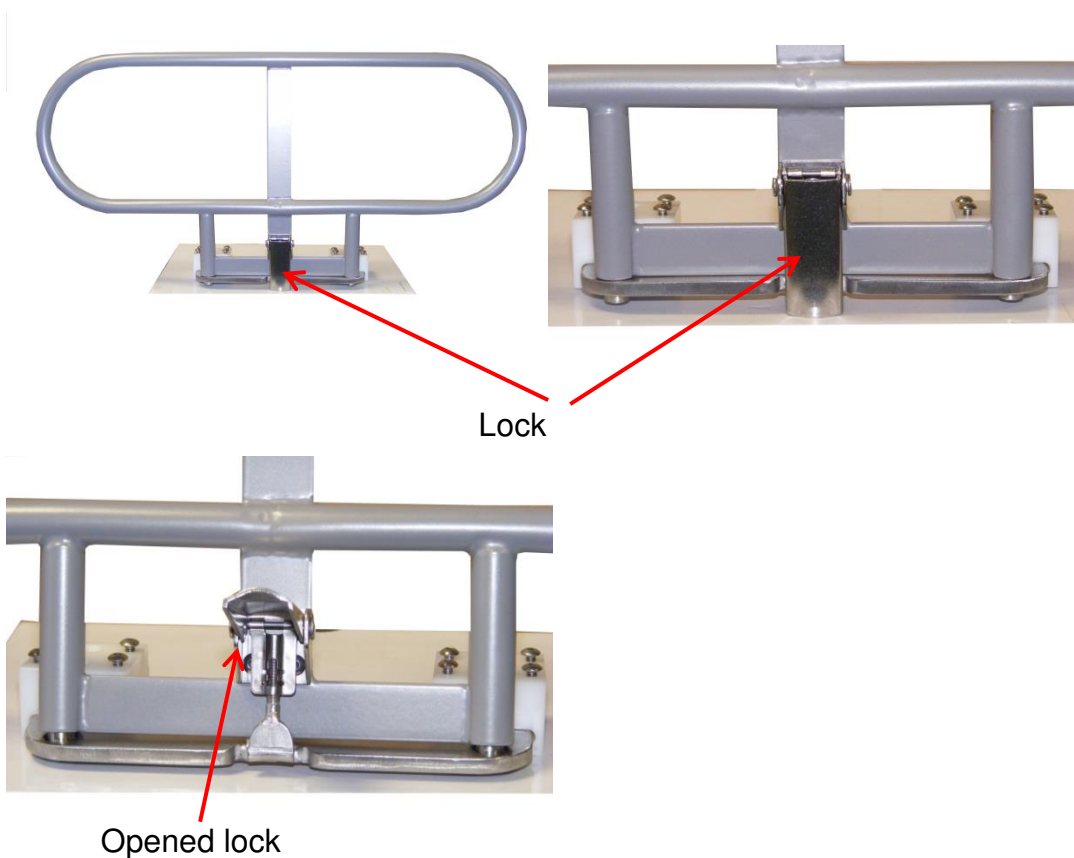

2. Pull the closing flap forward

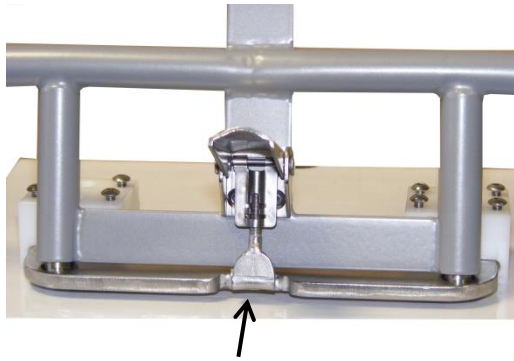

Closing flap

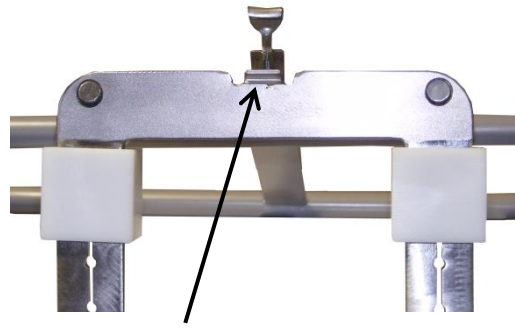

unlocked flap

3. Remove the side rail by pulling upwards.

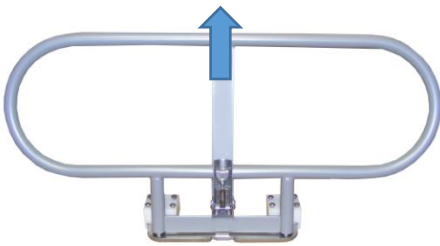

Removed side rail

Re-assemble in reversed order.

8.7 The armrest (option)



The armrest can be folded forward, backward or completely out. You can use the armrest on either side.

8.7.1 Assembly/disassembly of the armrests

To remove a safety armrest, turn it until both red markings on the safety armrest and its opening are opposite of each other.



Markings

Now, you can remove the safety armrest by pulling.

The safety armrest is assembled in reverse order.

WARNING:



Prior to raising or lowering the SENTA, the arm must be folded in front position!

8.8 Operating the SENTA PUR L

The seat of the SENTA PUR L combination bathing lift is raised or lowered by means of the handset, which is included in the delivery.

- Pushing the  button raises the seat.
- Pushing the  button lowers the seat.

Please check that no obstacle is underneath the seat when the seat is moving.

The SENTA PUR L combination bathing lift is equipped with an automatic protection device against collision.

If the device encounters an obstacle during the lowering procedure, the electrical motor is automatically switched off. In this case, raise the lift and remove the obstacle. After that, you can use the lift as usual.

The rear castors are equipped with parking brakes. **Engage the castors when lifting a patient** in order to avoid any unintentional and uncontrolled movement of the SENTA PUR L combination bathing lift.

Travel path

When using the SENTA PUR L combination bathing lift, make sure that the travel path of the combination bathing lift is not narrowed by obstacles or other elements (e.g. wall racks, etc.). Remember also that the maximum height is limited to 1375 mm. Take extreme care when passing through door frames.

When the battery is folded back, the bathing lift can pass through a door with a clearance width of 90 cm. In this case, it is irrelevant whether you use the bathing lift as seat either as stretcher lift.



Standard position



Battery folded back

NOTE:

The battery must be returned to standard position once you have passed through the door.

8.9 Lifting the patient from a bed

Please proceed in the following way to lift a patient from a bed:

1. Align the SENTA PUR L combination bathing lift with the bed of the patient.
2. Fold back both safety armrests.
3. If necessary, lower the side rails of the patient's bed
4. Turn the patient on his/her side.
5. Position the reclining surface or the seat of the SENTA PUR L over the mattress.
6. Engage the brakes of the SENTA PUR L to lock the castors.
7. Now turn the patient onto the reclining surface/seat of the SENTA.
8. Fold the front armrest down, so that the patient can hold onto.
9. Help the patient adopting a sitting position; as soon as the patient is in sitting position, fold the rear armrest (with backrest cushion) down.
10. Fasten the safety belt.
11. Disengage the parking brakes of the castors
12. Raise the lift until it can be removed from the patient's bed.
13. Lower the lift to transport height and drive the patient to the bathroom to bathe/shower.

CAUTION:

Do not lift the patient/resident higher than necessary.

8.9.1 Getting autonomously onto the seat lift

1. Engage the parking brakes.
2. Fold the safety armrests back.
3. Lead the resident/patient to the seat of the SENTA.
4. Install the patient/resident backwards on the seat
5. Lower the backrest.
6. Fold the safety armrest forward.
7. Secure the patient/resident with the belt.
8. Raise the SENTA and transport the patient/resident.

Caution: Please observe the sitting direction of the patient/resident!



False



Correct

CAUTION:



Do not lift the patient/resident higher than necessary.

8.10 Transferring a patient into a bath tub

CAUTION:



Do not lift the patient/resident higher than necessary.

Proceed as follows to install a patient/resident in a bath tub using the combination bathing lift:

1. Lower the bath tub to the bottommost position.
2. Raise the bathing lift so that the safety distance between the seat or stretcher of the lift and the tub edge is approx. 10 cm. When setting the height, you must ensure that there is sufficient lateral distance between the SENTA PUR L and the bath tub.
3. Position the SENTA diagonally to the head end of the bath tub. **Note:** *Help the patient/resident to raise his/her legs over the tub edge into the tub.*
4. Let the patient/resident check the water temperature with his/her foot. Adjust the temperature if necessary.
5. Align the SENTA PUR L centrally above the tub.
6. Set the bathing lift to a comfortable working height.
7. Raise the bath tub. *Make sure that no body parts are located between the bathtub floor and the bathing lift. (risk of crushing)*

CAUTION:



Do not raise the bath tub to such extent that the lift is lifted together with the tub! (tipping hazard)

Risk of injury for patient/resident and caretaker.
The bath tub and/or the lift could be damaged.

8. If the patient/resident is capable of sitting autonomously, you can fold the swing arm back and loosen the safety belt.
9. Bathe the patient/resident.



False



Correct

8.11 SENTA PUR with digital scale SL (option)

The digital scale SL consists of a handset and a registration unit.
The SL scale is destined to measure forces and weights.

It is a non-calibrated scale.

The following units can be set: N, kN, g, kg, t or lb. With the SENTA PUR L, you can weigh persons up to 150 kg at the most.



Image
Digital scale SL

Taste	Bezeichnung im Messmodus	Funktion im Messmodus (graue Beschriftung)	Bezeichnung im Menü	Funktion im Menü (hellblaue Beschriftung)
	NULLSTELLEN/TARIEREN	- Nullstellen/Tarieren und - Spitzenwerte löschen	hoch	- hochblättern im Menü - Zahlenwerte hochsetzen
	PEAK	Umschalten zwischen der Anzeige: - des aktuellen Messwertes - des Maximalwertes (= größter Wert in positiver Krafrichtung) - des Minimalwertes (= größter absoluter Wert in negativer Krafrichtung)	runter	- runterblättern im Menü - Zahlenwerte runtersetzen
	EIN/AUS	Gerät ein- / ausschalten	escape	- Menü verlassen, zurückkehren in Messmodus - bei der Eingabe von Ziffernfolgen zurückgehen zur vorherigen Ziffer
	MENU	Aufruf des Menüs	enter	- ausgewählten Menüpunkt aufrufen - Eingabe bestätigen und speichern

8.11.1 Safety instructions digital scale SL

All persons involved in the setting and the maintenance of the SL scale, must:

- have been instructed and trained accordingly,
- have read and understood the operating manual and observe the instructions contained therein,
- ensure that the safety instructions are respected and observed.

8.11.2 Cleaning the scale

Wipe the scale off with a damp cloth.

Never use abrasive or corrosive cleaners.

8.11.3 Using the scale

In order to ensure a proper operation of the scale, please observe the following:

- **Prior to Weighing:**

Push the on/off button to switch the scale on.

Wait until the scale is automatically tarred to 0.0 kg.

- **Preparing the weighing procedure:**

- Position the patient/resident onto the SENTA PUR L combination bathing lift.
- Make sure that the patient/resident is sitting or lying completely on the combination bathing lift and that the weighing procedure is not influenced by the patient/resident partly resting on e.g. a chair, a wheelchair, a bed.
- The correct weight of the patient/resident is now shown (in 0.1 kg steps).

Caution:

When calculating the weight, please observe that the proper weight of the clothes of the patient/resident must be deduced from the displayed weight to determine the actual body weight.

- The scale can now be switched off by pressing the on/off button.

8.11.4 Zeroing and Taring

Push the →0/T← button to zero the digital scale prior to a weighing procedure and without initial load. With this function, you can tare initial loads (sling, stretcher lift wings, straps) as well. These initial loads must be correctly applied prior to the weighing and tarred by pushing the button.

8.11.5 Replacing the Batteries

The state of charge of the batteries is monitored by the digital SL scale. If the battery is running out, the bottom row of the display “Batt” is flashing. In order to ensure the safe operation of the digital SL scale, the battery must be immediately replaced (**4 x 1.5 V AA-type batteries**).

8.12 SENTA PUR with calibrated scale (option)



Calibrated scale

8.12.1 Calibrated application

Only correctly sealed appliances may be used in calibrated applications.

It is the operator's responsibility to ensure this.

It is possible to configure device settings beyond the calibration regulations

You must always check whether the settings of the particular case meet the legal provisions.

The BEKA Hospitec EDI 03 is a high-precision digital weight indicator, based upon the latest sigma-delta A/D-technology. This provides for an accurate and fast weight display.

8.12.2 Homologations and approvals

According to EN 45501 OIML up to 4000d for non-automatic weighing instruments of Class III and IIII.

CE marking.

8.12.3 Product features

The EDI 03 weight indicator is suitable for simple weighing applications with tare and print functions.

8.12.4 Embedded functions:

- Battery-operated and mains-operated through connector part.
- RS232-interface for printing, PC communication or second display.
- 2 digital limit value outputs with status indication.
- Function key <f> for counting scale, weighing of persons, peak value display, hold or kg/lb conversion.
- Real-time clock and NVRAM to save the current values such as tare value, zero point, etc.

8.12.5 Environmental conditions:

Ambient temperatures: -10 to 40°C

Humidity: < 90%

NiMh-battery operation: 9.6 V DC

Permanent power supply: 12 – 24 V DC, 2.5 W max.

8.12.6 Electrical safety

Please make sure that you respect and observe the ambient conditions, for your safety. Always disconnect the device from the mains during maintenance and/or repair works.

8.12.7 Cleaning

Never use aggressive cleaners or solvents.
Clean with damp cloth and mild soapy water.



8.12.8 Field of application

The **EDI 03** weight indicator is not suitable for use in explosion-hazard areas. The protection class of the device is IP X5.

8.12.9 Waste disposal

Remove the batteries prior to the device's disposal.
Used batteries must be disposed of in accordance with the environmental regulations.

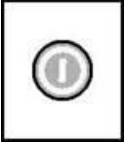
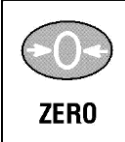
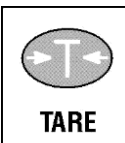

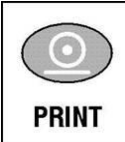
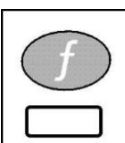



8.12.10 Operating the Scale

Button	Description
	<p>The device is switched on/off by means of the <POWER> button.</p> <p>To switch the device off, keep this button pressed for 3 seconds.</p> <p>When the device is battery-operated, the background lighting is automatically switched off. Press <POWER> to switch the lighting back on.</p> <p>The <POWER> button has a memory function. After a power failure, the original state is restored, i.e. if the device was switched on, it will be switched on again. In this way, once switched on, the device will always remain available, as soon as it is supplied with power.</p>
 <p>ZERO</p>	<p>If an empty scale shows deviations from zero, you can use this button to zero the scale. The weight indicator EDI 03 saves the zero point in the absence of power, as a result of which this parameter is maintained even in case of power failure.</p>
 <p>TARE</p>	<p>This button tares the scale. The display changes to 0 and the status bar displays NET.</p> <p>The <TARE> button is active for the entire possible weighing range.</p> <p>This concerns a subtractive taring, i.e. the weighing range is reduced by the tare value. The tare value is saved power-failure-proof by the EDI 03 weight indicator.</p>
 <p>GROSS/NET</p>	<p>Switches between gross and net.</p> <p>To this effect, a tare value must be available.</p>
 <p>PRINT</p>	<p>If a printer is connected and the printing function is activated in the menu, press <PRINT> to read a weight value; on the display, the message PRINT is displayed and the data are sent to the printer.</p> <p>If no printer is connected, the device will wait for 10 seconds at the most prior to cancelling the operation.</p> <p>Every printed weight value will be automatically added to the totalizing memory.</p> <p>Holding the <PRINT> button will print the total.</p> <p>After that, the totalizing memory will be deleted.</p>
	<p>Upon delivery, the function HOLD is assigned to this button. It is possible to freeze the weight display by means of the HOLD button. The HOLD symbol will appear on the screen. If you press the HOLD button once more, the normal weight display will be reactivated.</p>

8.12.11 “Stable Error” error message

If the buttons <ZERO>, <TARE> or <PRINT> are pressed, the scale will wait for a stable weigh cell signal before executing the function.

If no stable signal is reached within 10 seconds, the message **STABLE ERROR** will be displayed on the screen and the operation will be cancelled. Repeat the action if necessary.



Symbol	Name	Description
	Zero loop	Gross display within $\pm 1/4d$.
NET	NETT (Nett)	The scale has been tarred.
	MOTION (agitation)	Scale in motion
	Upper limit value	Weight higher than the set limit value. Target high.
	Lower limit value	Weight lower than the set limit value. Target low.
	Zero range	Weight value within the zeroing range
	Hold	The display is on hold
	Battery	Battery low, connect power supply unit or replace batteries/charge battery.

8.12.12 LIVE WT

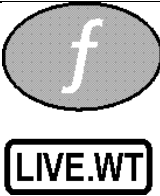
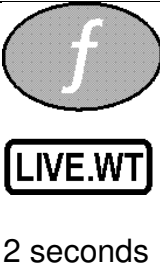
By means of this function, you can weigh persons, whose weight is strongly varying because of their permanent agitation.

<p>If you briefly press <LIVE WT>, the function is identical to <HOLD>.</p>	
<p>Press <LIVE WT> for 2 seconds to switch between the weighing of persons and the normal weight display. The display then briefly shows NORMAL or LIVE.WT.</p>	 <p>2 seconds</p>

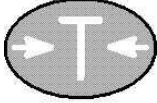
In **LIVE WT** mode (weighing of persons), proceed as follows:

<p>If the device is within the zero range, the weight is displayed normally, i.e. the Live-WT function is deactivated.</p>	
<p>Press the <TARE> or <ZERO> button to set the emptied scale to zero.</p>	 TARE
<p>Put the person on the scale.</p>	
<p>As soon as the weight is outside of the zero range, an average is calculated over a longer period of time. After that, the device displays Hold, the weight display is "frozen" and the device emits a beep.</p>	
<p>Press the <LIVE WT> button once more to trigger a new average calculation.</p>	 LIVE.WT
<p>As soon as the gross weight is within the zero range, i.e. the scale is emptied, the process can be repeated.</p>	

8.12.13 Error message in operation

Error	Description	Measure
(U - - - -)	Scale underload	Increase weight or switch scale off and back on.
(O - - - -)	Scale overload	Reduce weight.
(TARE) (ERROR)	Taring trial outside of authorised range. (Calibrated scales must only be tarred e.g. in case of a positive gross weight).	Change weight.
(ZERO) (ERROR)	Zeroing trial outside of authorised range.	Change weight or switch scale off and back on.
(STABLE) (ERROR)	A <ZERO> , <TARE> or <PRINT> command cannot be executed in the absence of a standstill.	Repeat the procedure when the scale is stable.

8.12.14 Error message in setup mode

Error	Description
(ENTRY) (DENIED)	You have tried to change/set a parameter in SAFE set-up, which is only possible in FULL set-up.
(LIN.PT (LO)	Trial to linearization underneath the zero point
(PT.TOO) (CLOSE)	Adjustment points are too close to one another (<2%) Adjustment impossible. Use other (usually higher) weights.
(RES) (LO)	Too little calibration values (<100) set.
(RES) (HIGH)	Too many calibration values set.
(SPAN) (LO)	Weighing cell signal too low for this setting
(SPAN) (HIGH)	Weighing cell signal too high for this setting or will become too high in case of full load.
(ZERO) (LO)	Zero point below -2mV/V
(ZERO) (HIGH)	Zero point above +2mV/V

8.12.15 Diagnostic error messages

Error	Description	Remedy
E0001	Voltage supply too low	Check
E0002	Voltage supply too high	Check
E0010	Temperature too high/low (-10 to +50°C ambient).	Check local conditions
E0020	Incorrect scale division (target between 100 and 30000 parts).	Change value
E0100	Settings are lost	Repeat settings
E0200	Scale adjustment is lost	Re-calibration
E0300	All settings and scale adjustment are lost.	Completely reconfigure settings and calibrate
E0400	Factory settings are lost (FATAL).	Service
E0800	EEPROM defect (FATAL).	Service
E2000	Wrong power supply to weighing cells.	Check weighing cell cable
E4000	Battery-buffered memory lost.	Repeat settings
E8000	FLASH memory defect (FATAL).	Service

The E – error messages are additive. Example:

- E0012 (E0010+E0002) indicates that both the voltage supply is too high and the temperature too high.
- E0C00 (E0800+E0400) indicates that the factory settings are lost and the EEPROM is defect.

8.12.16 Charging the battery of the calibrated patient scale:

The patient scale is supplied with voltage through an 8-cell nickel/metal hydride battery pack.



Loading process:

1. Plug the charger in the socket.
2. Plug the DC connector of the charger in the charging socket, on the right-hand side underneath the scale cover of the SENTA lift.
3. The charging indicator will become red, the battery is being charged. The charging time for a completely discharged battery is 16 hours. (The capacity of the battery is 2700 mAh. This is sufficient for approx. 24 hours of weighing.)
4. The charging process is not automatically interrupted; therefore, you should terminate the charging process after the specified time.

9 Cleaning/disinfection

9.1 Cleaning the SENTA PUR L bathing lift

Clean the SENTA PUR L combination bathing lift with a soft, lint-free cloth. For thorough cleaning, use a cloth moistened with a mild soap solution. Clean the product **every day** and **prior to each use**.

To avoid damages, no abrasive cleaners must be used to clean the handset and keypad control units.

<p>NOTE</p> 	<p>Make sure that the system is not in operation during the cleaning activities.</p>
--	--

9.2 Disinfecting the SENTA PUR L bathing lift

<p>WARNING</p> 	<p>After each treatment, the SENTA PUR LIFT combination bathing lift must be completely disinfected with a disinfectant. In this way, any cross-contamination is avoided.</p>
--	---

With respect to transmission risks and contamination, you must disinfect your SENTA PUR L combination bathing lift **every day** and **prior to each use**.

The following products are suitable for the disinfection of the SENTA PUR L combination bathing lift:

- Alcohol 70% (e.g. Mikrozyd AF liquid)
- Aldehyde (e.g. Antiseptica kombi)
- Oxygen releasers (e.g. Perform or Descogen liquid)

<p>CAUTION</p> 	<p>Only disinfectants only when the bathing lift is not in use. Strictly respect and observe the manufacturer's instructions for the used disinfectant. Avoid direct contact with the concentrated product. If necessary, use gloves and safety glasses to protect your skin and eyes.</p>
---	--

9.3 Sterilising the SENTA PUR L bathing lift

The SENTA PUR L bathing lift is **not** suitable for sterilisation.

10 Checks/tests

In order to ensure a safe use of our combination bathing lift and the protection of the users and the patients, BEKA Hospitec prescribes an annual safety check.

We recommend a simultaneous maintenance of the device in order to conserve its full value.

The execution of the safety checks and maintenance must be documented and proven on request. Use to this effect the inventory (14.6).

The checks may only be conducted by adequately trained and qualified experts. The non-observance of this prescription could lead to injuries and jeopardise the safety of the product.

<p>NOTE</p> 	<p>In accordance with the UVV (accident prevention) regulations of the German employer's liability insurance association on mobile equipment which is used in special locations or installations, an annual check of the SENTA PUR L bathing lift must be carried out to the DGUV (German Statutory Accident Insurance Association) Prescription 3 (BGV A3).</p>
--	--

This check is only prescribed for Germany. In other countries, other requirements might be applicable.

<p>WARNING</p> 	<p>Do not conduct any cleaning, maintenance or test activities when the bathing lift is in use. This could cause danger to the user and the patient.</p>
---	--

Clean, disinfect the bathing lift **every day/prior to each use**.

Conduct a **weekly** visual inspection of all components, the power cable and all electrical connections. Conduct a functional test as well and clean the castors if necessary.

Conduct **every year** a maintenance, a safety check and DGUV prescription 3.

10.1 Maintenance of the 24 Volt battery

The battery and the control box must not be opened by the customer.

Repairs may be carried out only either by BEKA Hospitec or by companies authorized to this effect by BEKA Hospitec. If the battery is discharged, recharge it as soon as possible to extend the lifetime. Batteries stored in the warehouse/stock must be recharged every 6 months (a possible deep discharge may destroy the battery). The battery's lifetime basically depends on the charge (number of lifting cycles) and the charging state. It can amount up to 5 years. Have defective or worn out batteries, and defective charging units in general, replaced.

11 Waste disposal

11.1 Disposal of the packaging material

Please recycle the packaging materials of the SENTA PUR L combination bathing lift in accordance with the locally applicable regulations and laws.

11.2 Disposal of the product

The estimated lifetime of the device is 8 year.

At the end of the product's lifetime, contact your BEKA dealer, who will recycle the SENTA PUR L combination bathing lift in accordance with the locally applicable regulations and laws.

For an environmentally-sound disposal, the company BEKA Hospitec GmbH will provide more information in its capacity of manufacturer.

Please clean and disinfect the SENTA PUR L combination bathing lift prior to its disposal as well.

12 Troubleshooting/After-sales service

12.1 Troubleshooting help

Problems with the lift	Remedy
Stroke adjustment of the lift does not work properly.	<ul style="list-style-type: none"> a) Check if the emergency stop switch is released/pressed. b) Check that the cables of the control box are correctly connected. c) Check the battery's state of charge. d) Remove the battery pack and check the contacts for damage.
The lift remains in the top end position.	<ul style="list-style-type: none"> a) Check if the emergency stop switch is released/pressed. b) Check the battery's state of charge. c) Use the electrical emergency lowering feature to lower the patient/resident. (see 7.6) d) Use the mechanical emergency lowering feature to lower the patient/resident. (see 7.5)
The drive stops during the lifting procedure.	<ul style="list-style-type: none"> a) Battery low. Charge the battery. b) The maximum load is exceeded (max. patient weight).
The drive stops during the lowering process.	An obstacle is located below the seat. In this case, raise the lift and remove the obstacle.
The electrical positioning adjustment does not react.	<ul style="list-style-type: none"> a) Make sure that the handset is connected. b) Check the plug-in connector at the control box. c) Check the battery.
The control box emits a "beep" signal when operated.	Battery low. Charge the battery.
The handset does not work.	<ul style="list-style-type: none"> a) Check the connectors at the handset cable and the motors. b) Check the battery charging status (replace the battery by a fully loaded battery).
The up and down buttons of the handset do not respond.	<ul style="list-style-type: none"> a) Check if the emergency stop switch is released or pressed. b) Check the battery charging status (replace the battery by a fully loaded battery). c) Check that the cables of the control box are correctly connected.
The castors produce loud noises.	Clean the castors and replace them if necessary.
The combination bathing lift produces unusual noises.	Inform the after-sales service.
The combination bathing lift is damaged.	Inform the after-sales service.
The "Service" indication is lit.	The annual safety check must be carried out.

Problems with the charging unit	Remedy
The battery charger does not function.	a) Remove the battery and check the contacts for damage. b) Check the power plug.
The operating display of the charging unit is not lit.	a) Check if the charging unit is connected to a power outlet. b) Check the fuse of the power outlet.
The charging unit is connected to the power outlet, but the operating display is not lit.	a) Check if the wall outlet is supplied with power. b) Remove the battery and check the contacts for damage.
Problems with the battery	Remedy
The battery is placed correctly, but the indicator lights are not lit.	Inform the after-sales service.
The indicator light does not go out after multiple hours of charging.	The battery must be replaced. Inform the after-sales service.
The battery installed in the charging unit indicates that it is fully charged. However, when placed in the lift, just a few lifting cycles are possible.	The battery must be replaced. Inform the after-sales service.
When the handset is actuated, an acoustic signal is emitted and the indicator light (red) is on.	Check the battery's charging state.

When your SENTA PUR L combination bathing lift does not function properly and you cannot eliminate the error by means of the remedies listed in paragraph 12, please contact the customer service of your dealer either the manufacturer.

	<p>BEKA Hospitec GmbH Am Rübenmorgen 3 35582 Wetzlar Phone: +49(0)641-9 22 22-0 Fax: +49(0)641-9 22-22-20 info@beka-hospitec.de</p>
---	--

13 Assembly/disassembly

13.1 Handset



Unplug the connector of the handset from the control box and plug it into the new handset.

13.2 Rear castor replacement

Image 1:

Required tools:

- 1 ratchet 17 mm
- 1 open-ended spanner 22 mm
- 1 T-wrench 6 mm



Image 2:

Additional parts/tools:

- 1 rear castor
- 1 thread-locking fluid (medium tight)



Image 3:

Unscrew the screw by means of the 22 mm open-ended spanner.



Image 4:

Remove the castor from the carrier frame.



Image 5:

Apply thread-locking fluid onto the thread of the new castor.



Caution: The thread-locking fluid must dry at least 3 hours before the device can be loaded.

Should you use thread lock fluid from another manufacturer, the drying times specified by this manufacturer must be observed!

Re-assemble in reversed order!

13.3 Front castor replacement

Image 1:

Required tools:

- 1 ratchet 17 mm
- 1 open-ended spanner 22 mm
- 1 T-wrench 6 mm



Image 2:

Additional parts/tools:

- 1 front castor
- 1 thread-locking fluid (medium tight)



Image 3:

Remove the cover. Use the ratchet and T-wrench to remove the front castor.



Image 4:

The image shows the screw with retaining nut and spacer.



Image 5:

Insert the screw through the opening from top to assemble the new castor. Then install the spacer at the screw. Install the retaining nut from the bottom.



Image 6:

Prior to screwing a new castor, you must apply thread lock fluid (**medium tight at least 21 Nm**) to the thread of the screw.



Caution: The thread-locking fluid must dry at least 3 hours before the device can be loaded.

Should you use thread lock fluid from another manufacturer, the drying times specified by this manufacturer must be observed!

Re-assemble in reversed order!

13.4 Mounting plate for control incl. magnet

Image 1:

Required tools:

- 1 T-wrench 3 mm
- 1 ratchet 118 mm
- 1 chrome nippers
- 1 nut 8 mm



Image 2:

Remove the battery from the mounting plate by lifting it up. (as described in 13.5)



Image 3:

Unplug the motor cable from the control box.



Image 4:

Unplug the cable of the handset control from the control box.



Image 5:

Remove the retaining screw of the control box.



Image 6:

Remove the top retaining screw of the mounting bracket.



Image 7:

Remove the bottom retaining screw of the mounting bracket.



Image 8:

Loosen the magnet by means of the chrome nippers.



Image 9:

Unscrew the magnet manually after loosening.



Image 10:

Remove the 4 retaining screws of the fixation of the control box.

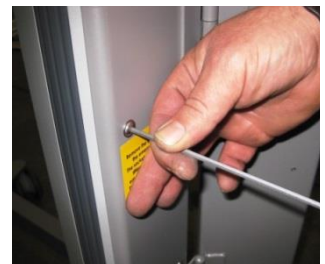

Image 11:

Remove the fixation of the control box.



13.5 Replacing the battery

Image 1:
The image shows
the inserted battery.



Image 3:
Pull the battery up
to remove it.

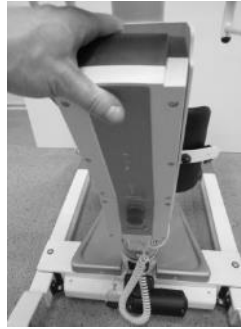

Image 2:
Unlock the battery
by means of the
release lever in the
battery handle.

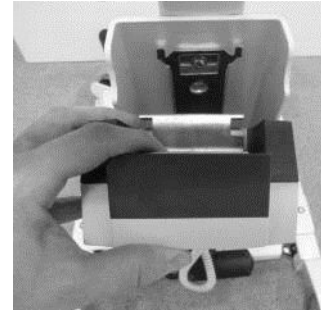

Image 4:
The image shows
the removed
battery.
When replacing the
battery, please
make sure that the
release lever
engages audibly.



14 Appendix

14.1 Technical data

Dimensions and weights	
- Length arm opened:	86.0 cm
- Length arm closed:	94.0 cm
- Width:	72.0 cm
- Height:	137.5 cm
- Seat height min.:	47.5 cm
- Seat height max.:	117.5 cm
- Wing width:	43.0 cm
- Wing length opened:	184.0 cm
- Accuracy of the scale:	100 grams
- Weight without packaging:	approx. 63 kg
- Turning radius:	R= 110.0 cm
- Safe Working Load (SWL):	max. 150 kg
Electrical data	
Control unit/Charging unit	
- Protection class:	Class II
- Applied part:	Type B
- Operating mode:	Short-term operation
- Input voltage:	100 V - 240 V~ (AC) / 50 / 60 Hz
- Output voltage:	24 V (DC)
- Power consumption	I in max. 1 Amp. / I out max. 10 Amp.
Spindle motor	
- Operating mode:	Short-term operation
- Input voltage:	24 V (DC)
- Power consumption	I in max. 7 Amp
- Protection class:	IP X4
- Duration of treatment:	2 min. continuous operation followed by 18 min. pause
Ambient conditions	
Operation	
- Temperature range:	10 °C to 40 °C
- Relative humidity:	30% to 75%, non-condensing
- Atmospheric pressure:	800 – 1060 hPA
Storage and transport	
- Temperature range (stand-up and raising aid):	- 40 °C to 70 °C
- Temperature range (battery):	- 15 °C to 40 °C
- Relative humidity:	10% to 80%, non-condensing
- Atmospheric pressure:	500 – 1100 hPA

14.2 Dimensions of the SENTA PUR L

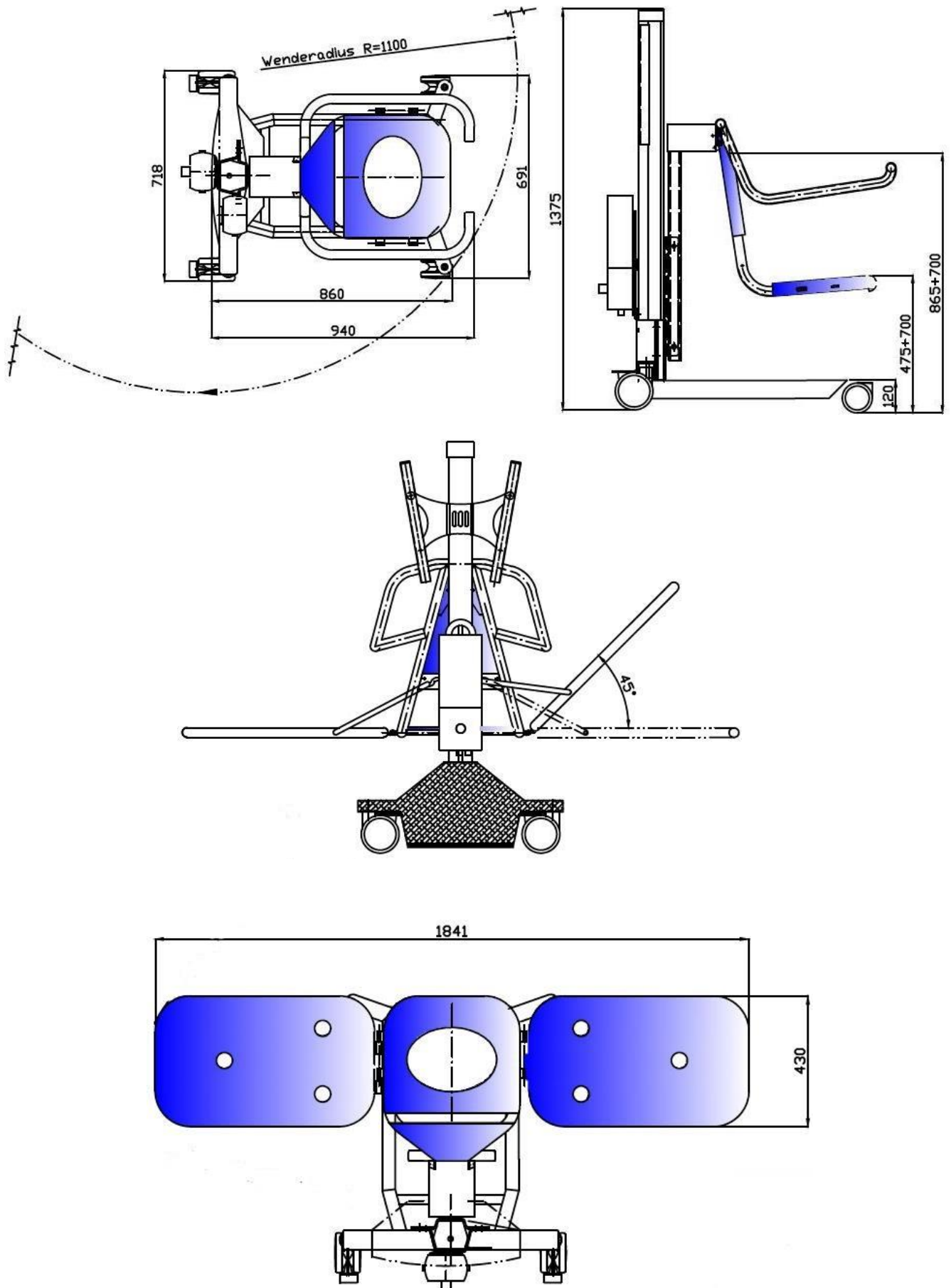

14.3 Declaration of conformity



EG-Konformitätserklärung / EC-Declaration of Conformity

Der Hersteller / The manufacturer

BEKA Hospitec GmbH
Am Rübenmorgen 3
D-35582 Wetzlar-Dutenhofen

erklärt in alleiniger Verantwortung gemäß EG-Richtlinie für Medizinprodukte 93/42/EWG Annex VII,
 dass die folgenden Produkte
*declares under sole responsibility according to the EU Medical Device Directive 93/42/EEC, Annex VII that
 the following products*

SENTA PUR L	Artikel Nr. P/N.	920101001 / 920101008
--------------------	---------------------	-----------------------

den grundlegenden Anforderungen entsprechen und die Voraussetzungen für die CE-Kennzeichnung erfüllen.
comply with the essential requirements and fulfill the provisions of CE marking.

Die Bauart der Produkte entspricht Klasse I des Medizinproduktegesetz (MPG), Regel 12.
The products correspond with Class I Medical Device Directive (MDD), Rule 12.

Zur Beurteilung wurden folgende Normen / Richtlinien herangezogen:
The following standards / directives apply:

EG-Richtlinie 93/42/EWG/ Directive 93/42/EEC		DIN EN ISO 14971:2013
DIN EN 10535:2007		DIN EN 60601-1:2007
DIN EN 12182:2012		DIN EN 60601-1-2:2007

Diese Erklärung trifft auf alle Produkte zu, die nach Ausstellung dieser Erklärung produziert wurden, bis sie
 durch eine andere Erklärung ersetzt wird.

*This declaration applies to all CE marked devices manufactured from the date of its issuance on until it is
 either superseded by another declaration or withdrawn.*

Technische Änderungen vorbehalten / Technical changes reserved.

Wetzlar, den 29.05.2017

Robert Deschler
 Geschäftsführer

BEKA Hospitec GmbH
 Am Rübenmorgen 3
 D-35582 Wetzlar-Dutenhofen
 Fon 0641 / 92 22 0-0
 Fax 0641 / 92 22 0-20

USt.-IdNr.: DE278603356
 Amtsgericht Wetzlar, HRB 6207
 info@beka-hospitec.de
 www.beka-hospitec.de

Geschäftsführung
 James Stuart-Smith
 Robert Deschler

Commerzbank AG Wetzlar
 Konto-Nr.: 482176500
 BLZ: 515 400 37
 IBAN: DE60515400370482176500
 SWIFT-BIC: COBADEFF515

14.4 Spare parts and accessories of the SENTA PUR L

Spare part n°	Description
K9201150	Handset
K9300270	Double castors 125 mm rear, with parking brake
K9200350	Double castors 100 mm front
K9200541	Control box CBJ
921070600	Spare battery 24 V
921070702	Wall charging unit (grey)

Accessory n°	Description
920104000	SENTA- PUR L digital scale SL (not calibrated)
920103000	SENTA- PUR L wing (stretcher lift module)
920103100	Side rails
920103115	Footrest SENTA- PUR L for side wings
920103120	Grab handle for stretcher lift

14.5 Electromagnetic Compatibility

Electrical medical equipment is subject to special precautionary measures with regard to EMC and must be installed and operated in accordance with the EMC instructions included in the accompanying documents.

For the devices and systems from BEKA Hospitec GmbH, no special measures must be observed.

Portable and mobile HF-communications equipment can interfere with electrical medical equipment.

Guidance and manufacturer's declaration - electromagnetic immunity (Table 201)		
The SENTA PUR L has been designed for use in the hereafter listed ELECTROMAGNETIC ENVIRONMENTS. The customer or the user of the SENTA PUR L must ensure that the appliance is used in such environment.		
Emission measurements	Compliance	Electromagnetic environment - guidelines
High-frequency (HF) emissions to CISPR 11	Group 1	The SENTA PUR L uses HF radiation exclusively for internal functions. Therefore, the HF radiation of the device is very low and any interference with adjacent electrical equipment is unlikely.
High-frequency (HF) emissions to CISPR 11	Class B	The SENTA PUR L is intended for use in any type of facility including living quarters and those that are directly connected to a public mains network that supplies residential buildings and buildings used for domestic purposes.
Harmonics to IEC 61000-3-2	Class A	
Voltage fluctuations/flicker to IEC 61000-3-3	Compliant	

Guidance and manufacturer's declaration - electromagnetic immunity (Table 202)			
The SENTA PUR L has been designed for use in the hereafter listed ELECTROMAGNETIC ENVIRONMENTS. The customer or the user of the SENTA PUR L must ensure that the appliance is used in such environment.			
Immunity testing	IEC 60601- Test level	Compliance level	Electromagnetic environment guidance
Discharging of static electricity (ESD) to IEC 61000-4-2	± 6kV contact discharge ± 8kV air discharge	± 6kV contact discharge ± 8kV air discharge	The floor must be in wood, concrete or ceramic tiles. In case of floors in synthetic material, the relevant air humidity must be at least 30%.
Rapid transient interference pulses/burst IEC 61000-4-4	± 2 kV for power supply cables ± 1 kV for input/output cables	± 2 kV for power supply cables not applicable to input/output cables	The quality of the supply voltage should match that of a typical business or hospital environment.
Overvoltage IEC 61000-4-5	±1 kV cable against cable ±2 kV cable against ground connection	±1 kV cable against cable ±2 kV cable against ground connection	The quality of the supply voltage should match that of a typical business or hospital environment.
Voltage drops, short interruptions and voltage fluctuations in the power supply input cables IEC 61000-4-11	<5 % U_T (>95 % drop of U_T) for 0.5 period <40 % U_T (>60 % drop of U_T) for 5 periods <70 % U_T (>30 % drop of U_T) for 25 periods <5 % U_T (>95 % drop of U_T) for 5 s	<5 % U_T (>95 % drop of U_T) for 0.5 period <40 % U_T (>60 % drop of U_T) for 5 periods <70 % U_T (>30 % drop of U_T) for 25 periods <5 % U_T (>95 % drop of U_T) for 5 s	The quality of the supply voltage should match that of a typical business or hospital environment.
Current frequency (50/60 Hz) Magnetic field IEC 61000-4-8	3 A/m	3 A/m	Power frequency magnetic fields should be at levels characteristic of a typical location in a typical business or hospital environment.
CAUTION U_T is the mains AC voltage before the application of the test level.			

Guidance and manufacturer's declaration - electromagnetic immunity (Table 204)			
The SENTA PUR L has been designed for use in the hereafter listed electromagnetic environments. The customer or the user of the SENTA PUR L must ensure that the appliance is used in such environment.			
Immunity testing	IEC 60601-Test level	Compliance level	Electromagnetic environment guidance
Conducted HF IEC 61000-4-6	3 Vrms 150 kHz up to 80 MHz	10 Vrms	<p>Portable and mobile HF communications equipment should be used no closer to any part of the SENTA including cables, than the recommended separation distance calculated in accordance with the equation applicable to the frequency of the transmitter.</p> <p>Recommended separation distance $d=0.35\sqrt{P}$ $d=1.2\sqrt{P}$ 80 MHz up to 800 MHz $d=2.3\sqrt{P}$ 800 MHz up to 2.5 GHz</p> <p>With P as the rated output of the transmitter in Watt (W) in accordance with the manufacturer's specifications and d as the recommended separation distance in meter (m).</p> <p>The field strength of fixed HF-transmitters as determined by an electromagnetic field survey, ^a – should be less than the COMPLIANCE LEVEL in each frequency range. ^b</p> <p>In the vicinity of equipment marked with the following symbol, interference may occur:</p> 
Radiation HF IEC 61000-4-3	3 V/m 80 MHz up to 2.5 GHz	3 V/m	
<p>NOTE 1: At 80 MHz and 800 MHz, the higher frequency range applies.</p> <p>NOTE 2: This manual could possibly not apply to all situations. Electromagnetic propagation is affected by absorption and reflection from structures, objects and people.</p> <p>^a The field strength of fixed RF transmitters, such as base stations of mobile phones and land mobile radios, amateur radio stations, AM and FM radios as well as radio and television broadcast media cannot be predicted theoretically with accuracy. To assess the electromagnetic environment due to fixed RF transmitters, an electromagnetic site survey is recommended. If the field strength measured in the environment where the SENTA PUR L is to be used, exceeds the applicable HF compliance level, special care should be taken that a normal operation of the SENTA PUR L can be guaranteed. In case anomalies are identified, additional measures could be required, such as a different alignment or a change of the location of the SENTA PUR L.</p> <p>^b In the frequency range from 150 kHz to 80 MHz, the field strength must be less than 10 V/m.</p>			

Recommended distance between portable and mobile communications equipment and the SENTA PUR L. (Table 206)

The SENTA PUR L is intended for use in an electromagnetic environment with controlled HF interferences. The customer or the user of the SENTA PUR L can avoid electromagnetic interference by respecting and observing the minimum distance between portable and mobile HF telecommunication devices (transmitters) and the SENTA PUR L depending on the rated output of the communication device as given below.

Rated output of the transmitter W	Separation distance depending on the transmitting frequency in m		
	150 kHz to 800 MHz $d=0.35\sqrt{P}$	80 MHz to 800 MHz $d=1.2\sqrt{P}$	800 MHz to 2.5 GHz $d=2.3\sqrt{P}$
0.01	0.04	0.12	0.23
0.1	0.11	0.38	0.73
1	0.35	1.2	2.3
10	1.1	3.8	7.3
100	3.5	12	23

For transmitters rated at a maximum output power not listed above, the recommended separation distance d in meters (m) can be determined using the equation applicable to the frequency of the transmitter, where P is the maximum output power rating of the transmitter in watts (W) according to the specifications given by the transmitter manufacturer.

NOTE 1: At 80 MHz and 800 MHz, the separation distance for the higher frequency range applies.

NOTE 2: These guidelines could not apply to all situations. Electromagnetic propagation is affected by absorption and reflection from structures, objects and people.

14.6 Journal

According to §13 of the Medical Device Directive, you are compelled to keep a journal for this device. You can use this journal as template.

Journal

Device: SENTA PUR L combination bathing lift

Manufacturer: BEKA Hospitec GmbH, Am Rübenmorgen 3, 35582 Wetzlar

Serial number: _____

Date of purchase: _____

Site: _____

Checks and inspection conducted upon the first use:

Date: _____

Evidence of the training session on the functions and the use of the SENTA PUR L

Instructor		Trained person	
Name	Date	Name	Signature

