

# Operation Manual



## Care Lifts

- #400001 Care Lift 475™
- #400019 Care Lift 600™
- #400000 LIBI Lift 475™
- #400003 Care Lift-n-Weigh 475™
- #400013 Care Lift-n-Weigh 600™

**IMPORTANT:**  
Read this manual  
before operating  
Medcare Lift and  
Stand equipment.



## Care Stands

- #450006 Care Stand Plus 440™
- #450007 CareStand-n-WeighPlus440™
- #400006 Care Stand 500™
- #400007 Care Stand-n-Weigh 500™
- #400021 LIBI Stand 350™

## Low Pro Lifts

- #450001 Low Pro 475™
- #450003 Low Pro Lift-n-Weigh 475™
- #450013 Low Pro Lift-n-Weigh 600™
- #450019 Low Pro 600™



## Car Extractor

- #450000 475™
- #450045 Low Pro 475™



# Introduction

Lifting patients is a challenging task that demands your utmost attention, skill and care.

This manual will show you how to use Medicare Lifts, Stands and Car Extractors to make lifting easier and safer. It is important that you use the proper lifting procedures indicated in this manual.

Learning the proper technique for safe, smooth and efficient lifts and transfers will help maximize the safety and comfort of staff and patients/residents. Medicare lifts and stands are not intended for the transportation of patients over long distances.

## Additional Instruction

Visit [www.medicarelifts.com](http://www.medicarelifts.com) for more visual detail and instruction of lift procedures. You can also schedule an in-person training session by contacting your Medicare Safe Patient Handling Consultant.

## Medicare Products

Call Medicare if you need operating or technical assistance.

We are always ready to help you in any way we can.

[www.MedicareLifts.com](http://www.MedicareLifts.com)

1-800-695-4479

Monday-Friday 8:00 a.m. – 5:00 p.m. CST

Medicare Products, Inc. certifies that we have tested our stands and lifts and have found that one trained health care professional can safely lift/transfer patients/residents in either our lift or stand (with the exception of the Car Extractor). Medicare lifts and stands are not intended for use as a transport device over long distances. In no circumstances should our lifts and stands be used to lift patients/residents unless the equipment operator/caregiver has been trained in accordance with these procedures. Use of the stands or lifts without proper training could result in serious injury to the equipment operator or the person being lifted/transferred. Our standards and procedures can be found in our Operation Manual and training video. Our Operation Manual can also be found on our website at [www.MedicareLifts.com](http://www.MedicareLifts.com).

While we believe that one person can safely operate our equipment, each facility has its own policies and procedures regarding the safe lifting and transfer of patients/residents. In the event that your facility's policies require more than one staff member to safely perform a patient/resident lift/transfer with a mechanical lifting device, that policy should be followed. We advocate that your facility staff members follow your policies and procedures in all circumstances.

If you have any questions regarding the ability of our stands and lifts to safely lift/transfer patients/residents or the ability of one health care professional to safely operate our lifts and stands, please feel free to contact us. If you need copies of our Operation Manual or training video, please contact your Medicare Safe Patient Handling Consultant.

# Contents

Page	
2	.....Introduction
3-4	.....Assessment
5-8	.....Care Lift Operations
9-10	.....Care Stand Operations
11	.....Car Extractor Operations
12	.....Sling and Belt Safety Instructions
13	.....Sling Washing and Care Instructions
13	.....Sling Sizing Guide
14	.....Calibration Instructions
14	.....Weighing Procedure
15	.....Battery Charging
16	.....Parts List – Lift
17	.....Parts List – Stand
18	.....Parts List – Car Extractor
19	.....Parts List – Low Pro Lift
20	.....Care Lift and Stand Accessories
21	.....Limited Warranty
22-23	.....Troubleshooting Guide
24	.....Routine Maintenance Overview
25	.....Preventive Maintenance Checklist
26-27	.....Order Form

**IMPORTANT:** Any injuries that occur to patients or caregivers in connection with the use of Medicare equipment should be reported to Medicare Products immediately.

# Assessment

The Medicare Lift is intended for patients who are non-weight-bearing and require total lifting to perform the activities of daily living.

The Medicare Stand was designed specifically for assisting your patients to a standing position. Once in a standing position, you or your staff can safely perform a number of patient care tasks. The Medicare Stand may also be modified to be used as an attended walking device.

Because the Stand is an assistive device, it should only be used with patients that can bear the requisite amount of weight as determined by your facility. It also requires that patients possess more advanced motor and cognitive skills than for the Medicare Lift. It is important to first determine the appropriateness of this piece of equipment for a particular patient.

If you need help in assessing a patient's weight-bearing ability, please ask your therapy department for assistance.

Equipment Dimensions and Specifications					
	Lift	600 lbs Lift	440 lbs Stand	500 lbs Stand	Low Pro
Overall Length	47"	47"	39.5"	39.5"	48"
Width – (outside) legs closed	24"	24"	25"	25"	27"
Max Width – (outside) legs open	46"	46"	39.25"	39.25"	44.5"
Height of Wheel Base	4.5"	4.5"	4.5"	4.5"	2.25"
Total Weight of Machine	103 lbs.	103 lbs.	125 lbs.	126 lbs.	110/120 lbs.
Maximum Load Capacity	475 lbs.	600 lbs.	440 lbs.	500 lbs.	475/600 lbs.
Maximum Height	81.5"	81.5"	NA	NA	80"
Power Source	Rechargeable 24 volt: 12 AH batteries				
Operating Mechanism	Electronic ball screw actuator				
Width - (inside) legs closed	20"	20"	20"	20"	18.5"
Max Width - (inside) legs open	38"	38"	34.25"	34.25"	36.5"

Care Lift



Care Stand

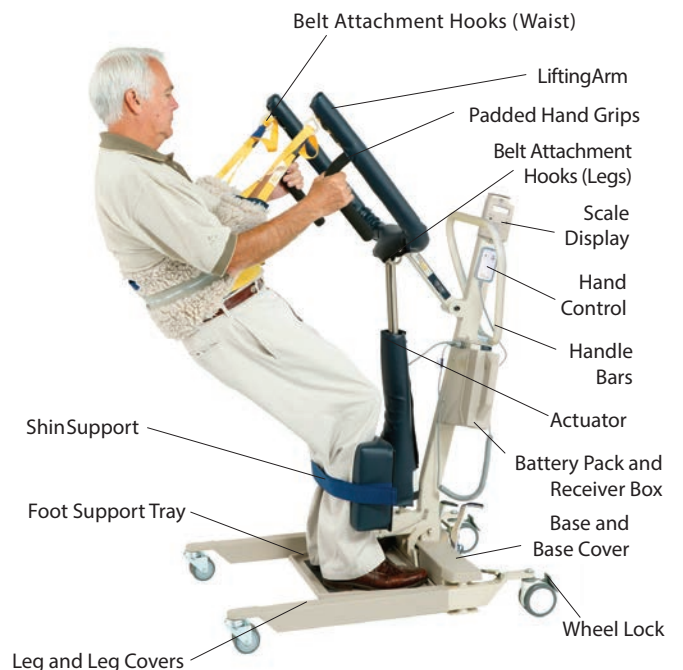

## Assessment (cont.)

The Medicare Car Extractor was designed to safely lift and remove or insert patients from nearly any vehicle, from a compact automobile to a fire/emergency van. The Medicare Car Extractor should not be used for the transportation of patients over long distances.

Built light and strong, with a 30” reach and a 40” lifting range, the Medicare Car Extractor can gain deep access into tight vehicle interior spaces and lift large patients with limited mobility or little weight bearing ability — up to 475 lbs. capacity.

Equipment Dimensions and Specifications	
	Car Extractor
Overall Length	47"
Width – (outside) legs closed	25"
Max Width – (outside) legs open	43"
Height of Wheel Base	4.5"
Boom Arm Reach	30"
Maximum Height	85"
Maximum Load Capacity	475 lbs.
Power source	Rechargeable 24 volt, 10 AH batteries
Width – (inside) legs closed	20"
Max Width – (inside) legs open	38"

### Car Extractor



# Care Lift Operations

## Positioning sling for patient/resident in seated position

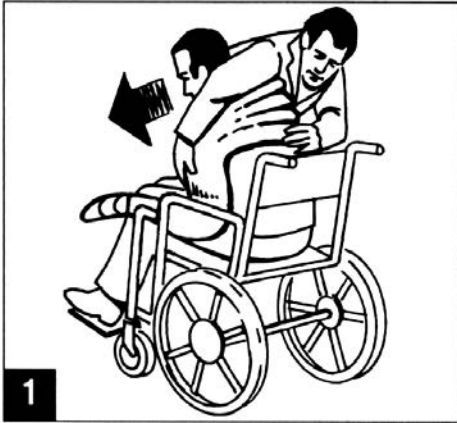

1 To position sling, gently lean patient/resident forward.

Position sling handles so they face away from patient/resident. Tuck the sling behind the patient/resident until it comes in contact with the seating surface.

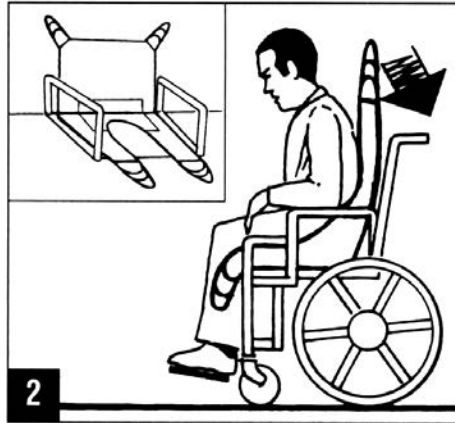

2 The sling should touch the seat of the chair, conforming to patient's/resident's tailbone area.

The top of the sling should rest on patient's/resident's shoulders, and the center positioning handle should be centered between the patient's/resident's shoulder blades.

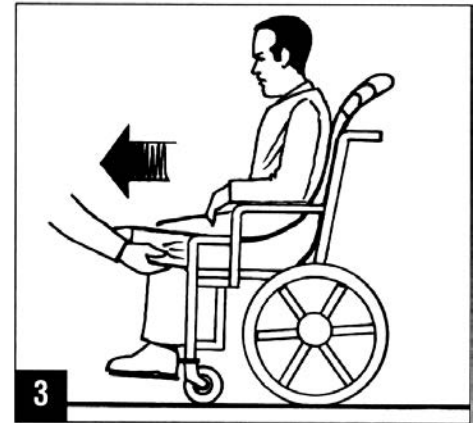

3 Position leg straps inside the arms of the chair.

Pull the leg straps of the sling toward you. Ensure no twisting has occurred.



4 Gently raise patient's/resident's thigh, pulling the leg straps underneath.

Repeat same procedure for other thigh.

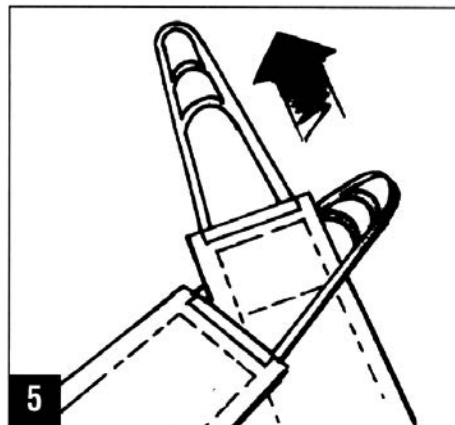

5 Criss cross the leg straps as shown with one strap passing through the other.

Attach straps to adjacent sling support hooks.

(See Attaching Sling to Care Lift instructions on page 7.)

**CAUTION:** When lifting and lowering from a wheelchair, do not lock the wheels of the Care Lift. Always lock the wheels of the wheelchair.

**CAUTION:** Do not place anything between the actuator and mast during operation of lift.



## Care Lift Operations (cont.)

Positioning sling under patient/resident from lying down position (bed or floor)

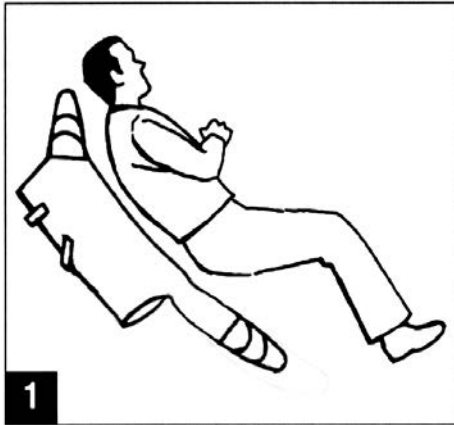

1 Fold sling in half, lengthwise.

Roll patient/resident to one side.

Place sling behind patient's/resident's back with center handle facing away from patient/resident.

Align lower sling webbing with patient coccyx, keeping center handle along the center of the patient's/resident's back. (see fig. 1)

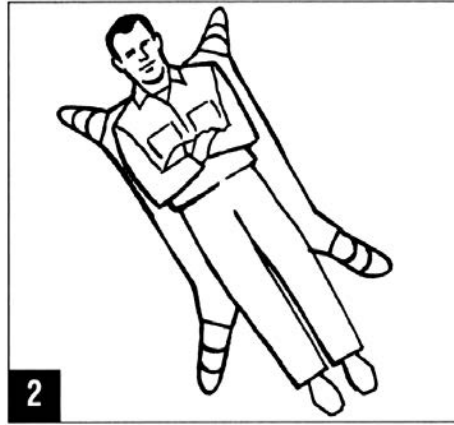

2 Roll patient/resident to the opposite side.

Pull sling flat, and then roll patient/resident onto their back. Ensure sling is centered under patient/resident. (see fig. 2)



3 Pull leg strap under patient's/resident's thigh. Ensure no twisting has occurred.

Repeat procedure with other leg.

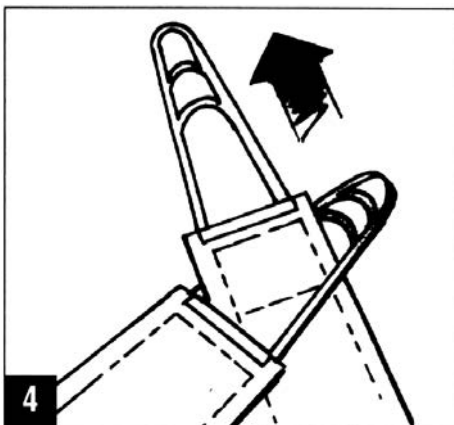

4 Criss cross the leg straps as shown with one strap passing through the other.

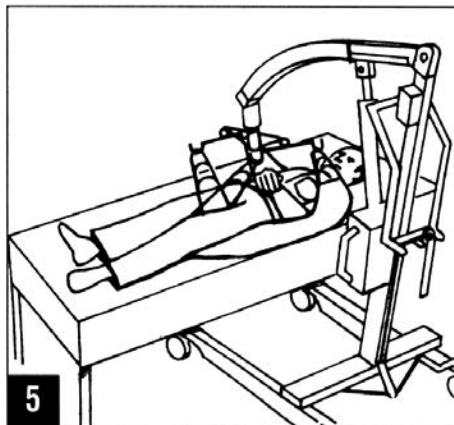

5 Prepare patient/resident for transfer by attaching sling to Care Lift. (see fig. 5)

Refer to patient positioning on page 8 for sling hook up options.

**CAUTION:** Always have bed rails up when rolling a patient/resident in bed.

## Attaching sling to lift



**1.a (SEATED)**

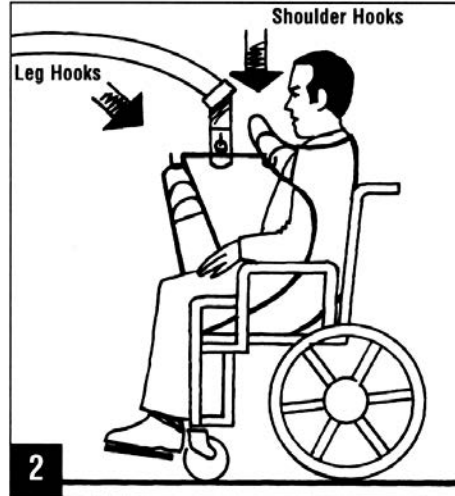

**2**

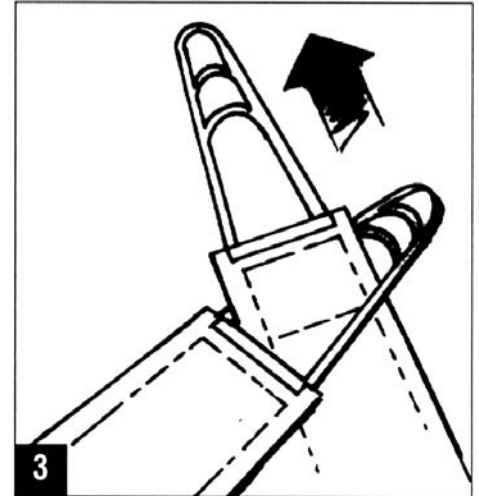

**3**

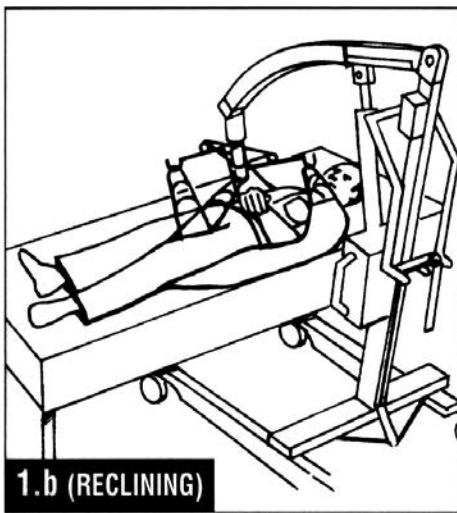

**1.b (RECLINING)**

Position carry bar so that it is parallel with the patient's/resident's shoulders.

Attach right shoulder strap to nearest sling support hook.

Repeat process for left shoulder strap. (see fig. 2)

Do not cross shoulder straps.

Criss cross the leg straps as shown with one strap passing through the other.

Attach right leg strap to nearest sling support hook.

Repeat process for left leg strap. (see fig. 2)

TIP: Diagrams show use of lift with standard slings. If the patient/resident has special needs and requires a different sling style, contact your Medicare Safe Patient Handling Consultant for sling options and training.

Position the Care Lift.

- A) Directly in front of a wheelchair or seated patient/resident.
- B) Perpendicular to bed or supine patient/resident.

# Care Lift Operations (cont.)

## Adjusting position of patient/resident in sling

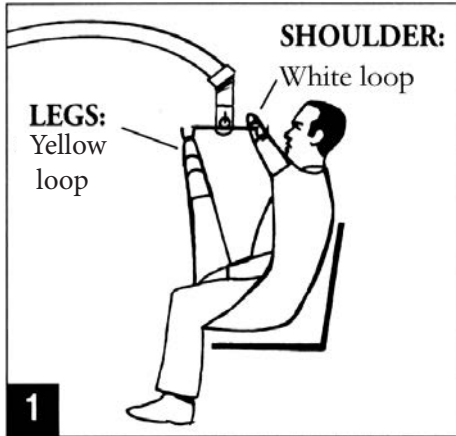

1 Upright position

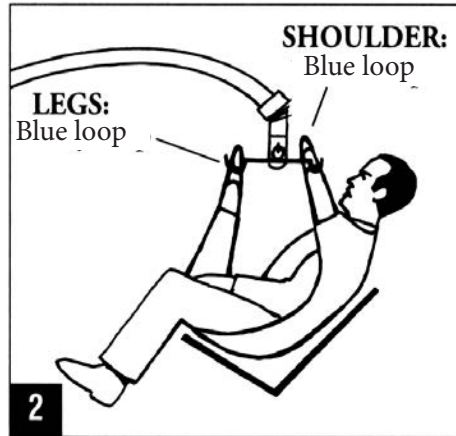

2 Partial reclining position

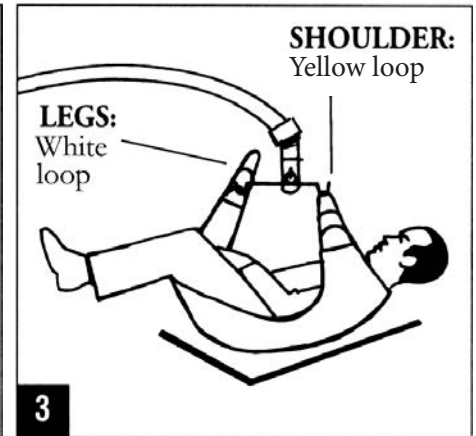

3 Full reclining position

## Lifting and transferring patient

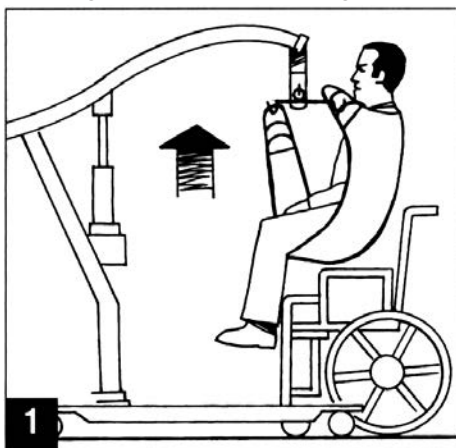

1 To properly move the lift, always use the handlebars. **Never push, pull or lift boom.**

Ensure a clear space is maintained around the lift. Move all obstacles out of the way prior to performing a transfer.

Raise the patient/resident by pressing the "Up" button on the hand control.

Lift patient/resident and transfer to desired location. Lifting and transferring should always take place within the wheel base of the lift and on level ground. When in position, begin to carefully lower patient/resident.

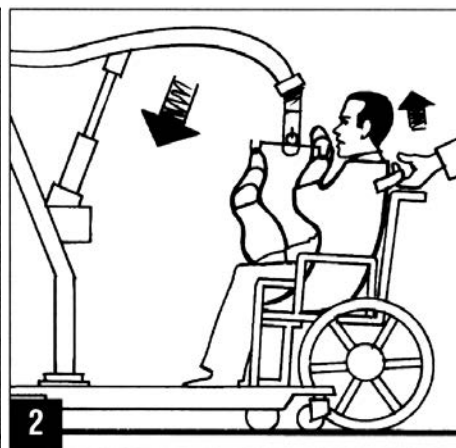

2 To properly position patient/resident in chair, push the "Down" button until they are seated.

After positioning patient/resident, remove straps from hooks.

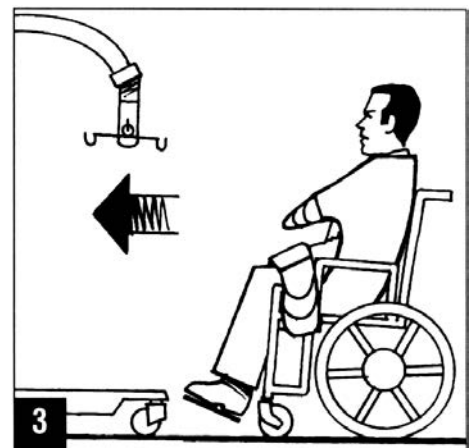

3 After removing sling straps, back lift away from patient/resident.

Remove sling from patient/resident by reversing sling application procedure. (found on pg. 5 & 6)

**IMPORTANT:** Prior to lifting an individual make sure that the straps of the sling are securely placed on the hooks of the carry bar.

**IMPORTANT:** This mobile lift is primarily intended to assist in the lifting or transferring of clients from one resting surface to another in the same room or area. It is critical that a thorough risk assessment be completed by your facility to understand the abilities of the caregiver and client.



# Care Stand Operations

## CARE BELT

### Belt features

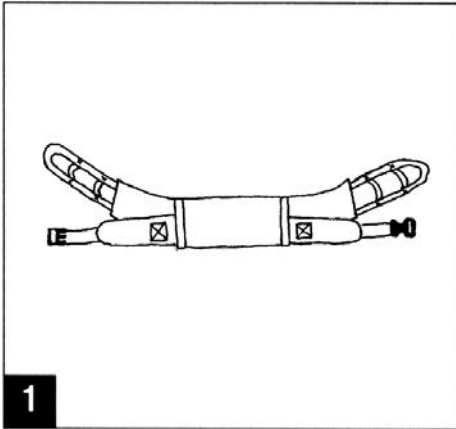

This belt offers support for patients/residents capable of standing upright.

### Positioning Care Belt around patient/resident in seated position



Position the belt around the patient's/resident's lower back, just above the belt line. (see fig. 2)

Fasten buckle to secure belt.

**TIP:** An assessment of each patient's/resident's ability to bear weight should be performed prior to using the Care Stand. If you need help in assessing a patient's/resident's weight-bearing ability, please ask your therapy department for assistance.

## TRANSPORT ATTACHMENT

### Transport Attachment features



The Transport Attachment slides over the belt to provide additional support to the lower extremities when needed.

### Applying Transport Attachment to patient/resident

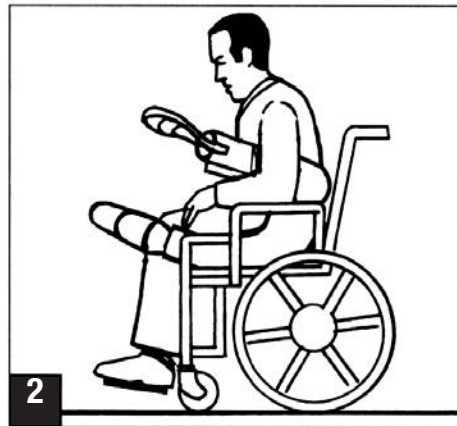

Position the belt around the patient's/resident's lower back, just above the belt line. (see fig. 2)

Fasten buckle to secure belt.

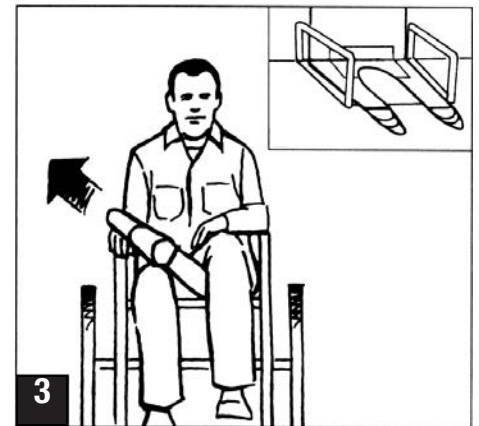

Pull the leg straps under the patient's/resident's thighs. Ensure no twisting occurs.

# Care Stand Operations (cont.)

## Positioning the Medicare Stand Attaching Care Belt to Care Stand

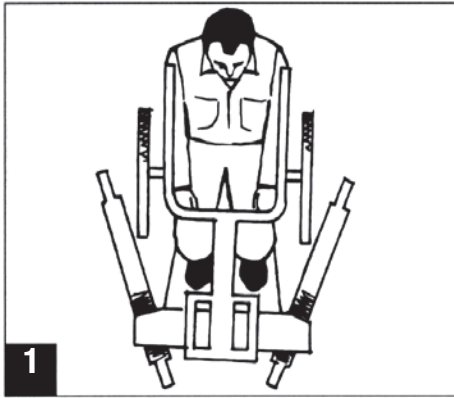

Open the legs of the stand with the foot pedal and position stand in front of patient/resident. (see fig. 1). Lock the wheels of the wheelchair.

**CAUTION:** When lifting from a wheelchair, always engage the wheelchair lock before proceeding.

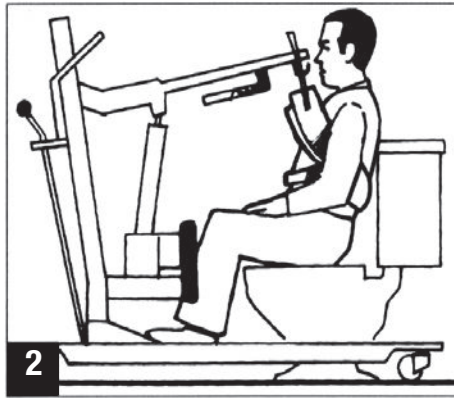

Assist the patient/resident in placing their feet on the foot plate with their shins against the support pad. If needed, fasten velcro strap around patient's/resident's lower legs (leg strap with buckle; part number 401013 is available upon request).

**IMPORTANT:** Patient must be somewhat weight bearing to use Medicare Stand. (see page 3)

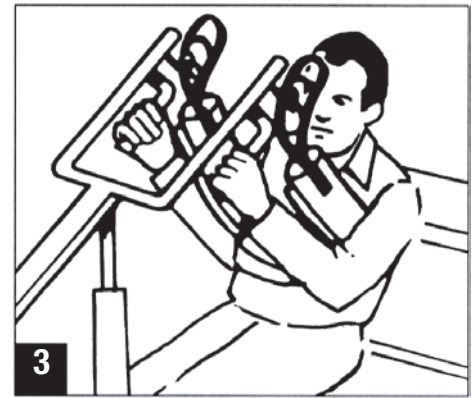

With the lifting arm in the lowest position, connect the attachment loops to the hooks on the stand. (see figs 2). Use the shortest straps whenever possible. (Make sure to use the same loop position on both sides.)

Position the patient's/resident's arms on the outside of the belt and place their hands on the padded handles. (see fig. 3)

## Raising patient/resident

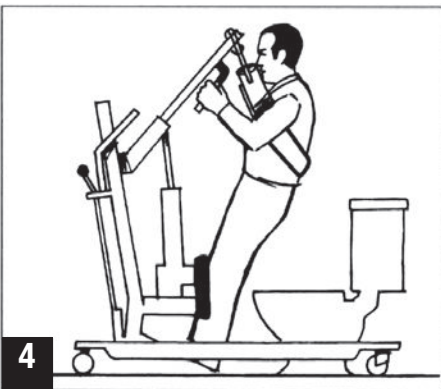

Raise the patient/resident to the standing position by pushing the "Up" button on the hand control. As you raise the patient, their abdomen will elongate. Retighten the belt strap to ensure it doesn't move up.

Lower patient/resident by pressing the "Down" button on the hand control. When patient/resident is seated, disconnect straps, remove belt and push stand away.

## Using the Care Stand as a walker

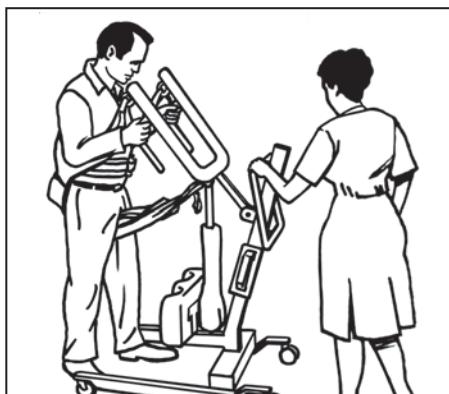

**CAUTION:** It is important to remain with your patient/resident at all times during this procedure.

The Care Stand can also be used as an ambulation aid.

Remove the foot plate located below the knee support. Lock the stand's wheels.

Attach the belt as explained previously.

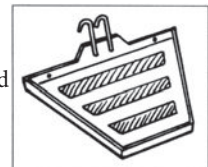

*Lift up and forward to remove.*

Ensure a clear space is maintained around the stand. Move all obstacles out of the way prior to performing a transfer. Raise patient/resident and unlock wheels. While assisting the patient/resident, begin walking by guiding the Care Stand in the appropriate direction. Raising and ambulation should always take place within the wheel base of the stand and on level ground.

Using the Care Stand as an ambulation aid requires more advanced skills by the patient/resident. Please check with your facility's physical therapist before using it in this manner.

# Car Extractor Operations

## Requirements



**Equipment:** Medicare Car Extractor, two Care Belts, and a Stretcher or wheelchair in immediate vicinity to transfer patient immediately upon extraction.

**Two persons** needed to operate lift

- One caregiver with the Car Extractor
- One caregiver guiding the patient inside the vehicle

## Applying Belts



1. Place Care Belt around patient's/resident's back, under arms, and fasten buckle at abdomen. Tighten by pulling on straps near buckle.
2. Place second belt under patients thighs above knees and fasten buckle on top. Tighten by pulling on straps near buckle.

## Connect to Car Extractor



1. Lower the boom on the Car Extractor enough to clear the car roof by pushing the "Down" button on the hand control.
2. Position boom into vehicle in front of patient/resident. Position hanger bar to be parallel to the patient's/resident's shoulders. Lock brakes.
3. Connect shortest loops possible from both belts to hanger bar.

## Extracting a Sitting Patient



1. Ensure a clear space is maintained around the Car Extractor. Move all obstacles out of the way prior to performing a transfer.
2. Raise the boom by pushing the "Up" button on the hand control, enough to raise the patient/resident from the car seat.
3. Rotate patient/resident so feet and legs are facing the exterior of the car.
4. Pull the extractor backwards as you guide the patient's/resident's feet out the door. Have a second person in the car support the patient's/resident's head.
5. Upon extraction from the car, the patient/resident should be immediately placed into a wheelchair, on a stretcher, or similar device for transportation. Lifting and transferring should always take place within the wheel base of the Car Extractor and on level ground.

# Sling and Belt Safety Instructions

## Important Notice

Medcare slings and belts have been specifically designed and tested for use with lifts or stands manufactured by Medcare Products, Inc. and any other lift with a 4 point hanger bar loop system.

Slings and belts are manufactured of high-quality fabric. However, if Medcare washing instructions are not followed, the integrity of the product cannot be guaranteed. A proper sling inspection process is recommended.

Accordingly, the purchaser hereby accepts full responsibility for inspecting the condition of all slings and belts before each use.

**IMPORTANT:** Immediately remove any damaged slings or belts from service.

## Inspection of Slings and Belts

Slings and belts should be inspected for wear and tear before every use.

The following items all have an impact on the life expectancy of a sling or belt:

- Water washing temperature
- Detergents and disinfectants
- Patient incontinence
- Frequency of use
- Types and weights of patients
- Age of sling or belt
- Drying temperature

## Sling/Belt Inspection Checklist

What to look for when determining if a sling should be replaced:

### Use of Bleach

The use of bleach for cleaning any Medcare manufactured sling is not encouraged. Using bleach will reduce the “life” of the sling. Bleach is known to speed up fabric deterioration while causing fading and discoloration. If your facility is using bleach to launder slings it is imperative to inspect for premature wearing on a regular basis. This will ensure a safe transfer for the patient and caregiver.

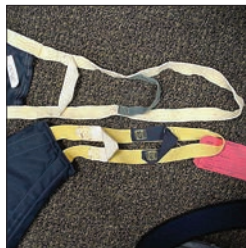

### Loose Stitching

Any loose stitching on the sling, even if it is only supportive stitching, weakens that area and puts more strain on other areas of the sling.

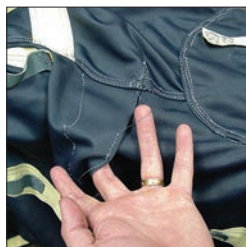

### Fraying

Any fraying of the material on the sling or belt is a clear indication that the fabric is in a weakened condition. Slings and belts with fraying should be removed from service immediately.

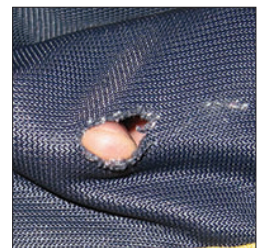

### Rips or Burns in Material

Tears in fabric can spread and cause excess strain to be put on other areas of the sling. Slings and belts with rips, tears or burns should be removed from service immediately.

### Time or Duration of Use

Over time, the integrity of the fabric can deteriorate. Some of this wear is evident through observation while some cannot be observed by the naked eye. Facilities should establish a policy to replace slings on a periodic basis regardless of the apparent conditions of the sling.



# Sling and Belt Washing and Care Instructions

- Machine wash in soap solution
- Maximum washing temperature = 165° F
- Rinse thoroughly
- Hang or tumble dry
- Maximum drying temperature = 175° F
- Do not overload dryer
- Do not place in direct contact with heat source in dryer
- Do not dry clean
- Bleach not recommended (VOIDS WARRANTY IF USED)

Medcare slings can be wiped down or spot cleaned between washings using your standard cleaning product (e.g. AHP)

## Sling Sizing Guide

Use this sling sizing chart as a general guide. Keep in mind that patients/residents that are the same weight may have different body types, shapes, and sizes and may require different sized slings.

Weight	Recommended Sling Size	Positioning Handle Color
0 - 100 lbs 0 - 45 kg	Small	Black
100 - 210 lbs 45 - 95 kg	Medium	Blue
210 - 310 lbs 95 - 141 kg	Large	Yellow
310 - 450 lbs 141 - 204 kg	X-Large	White
450 - 1000 lbs 295 - 454 kg	Bariatric	Purple



## Belt Sizing Guide

Use this belt sizing chart as a general guide. Keep in mind that patients/residents that are the same weight may have different body types, shapes, and sizes and may require different sized belts.



Waist Size	Recommended Belt Size	Positioning Handle Color
24" - 48"	Small	Black
30" - 54"	Medium	Blue
36" - 60"	Large	Yellow
42" - 66"	X-Large	White

# Weighing Procedure

For consistent weighing accuracy, follow these steps:

1. Push weight button.
2. Hang the empty sling on the sling support hooks. (see fig. 1)
3. Press the ZERO button on the display panel. 0.0 will be displayed.
4. Position patient/resident in sling.
5. Lift patient/resident off of surface.
6. Patient's/resident's weight displayed.

\* Use a fully charged battery to achieve the most accurate reading.

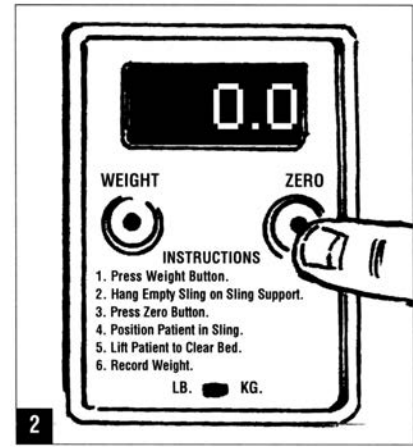

# Calibration Instructions

## Standard Scale Display (Tip: Use fully charged battery)

1. With the power off, hold down both buttons on the scale and turn the power on.
2. After five seconds, release buttons. The scale should now read CAL.
3. If calibrating a lift, place a sling on the hanger bars. Make sure the sling hanger bars are perpendicular to the boom. If calibrating a stand, skip this step.
4. Let the scale settle to a reading, then zero it out by pressing the "ZERO" key.
5. Place a 50 lb. weight in the sling (for lift) or on the foot plate (for stand). Note: Use a certified 50 lb. weight for this. Do not use a bag of sand, etc.
6. Once the display settles, press the "WEIGHT" button. The display should now read 50 lbs.
7. Take the weight off the scale and let the scale settle to zero. You have now finished calibrating the scale. The scale display exits on its own. There is no need to turn the power off.
8. Place the weight in the sling or on the foot plate again. The scale should read 50 lbs.

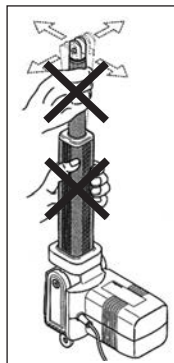

**CAUTION:**  
Do not shake or handle actuator or shaft.

**NOTE:** When taking weights, make sure the two hanger bars are perpendicular to the boom. This will give you the most accurate weights.

\* Use a fully charged machine battery to achieve the most accurate weights.

# Emergency Lowering of Actuator

In an emergency; if the actuator of your Care Stand or Care Lift will not lower, first verify first four digits of serial number located on lift or stand (If actuator was replaced during ownership, verify if Linak or SKF actuator was used.), then follow these instructions:

Month 08 12FS1971 Year

For lifts before August (08) 2013 (13):

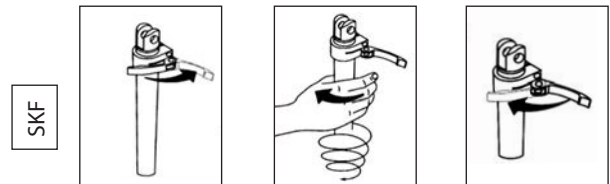

1. Open red collar

2. Turn shaft clockwise

3. Close red collar

For all stands and lifts on or after August (08) 2013 (13):

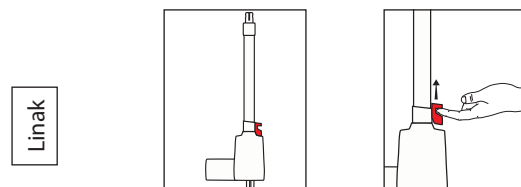

1. Locate red release button

1. Lift red release and hold

Contact Medicare Technical Support for additional questions about your actuator at 1-800-695-4479

# Battery Charging

## Charging Batteries

1. Slide charger housing plug into battery plug.  
An orange light on the charging unit indicates battery is charging. A green light on the charging unit indicates battery is fully charged. 6-8 hours are needed for a full charge.
2. Battery is now ready to use.



## Recharging batteries

A red light on battery receiver box indicates battery needs to be recharged. Do not allow battery to completely drain, as this will permanently diminish its charging capacity.

It is not necessary to remove battery pack from the charger until it is needed.

## Battery Charger



Medcare's battery charger is a solid state battery charger designed to charge, maintain and hold your Medicare Battery Pack to a full charge.

## Important Safety Instructions:

- To reduce risk of injury, charge only Medicare Battery Packs provided by Medicare Products.
- Do not let the charger get wet or use in areas prone to excessive moisture.
- Extension cords should not be used.
- Do not operate the charger with a damaged plug or cord.
- Do not use the charger if it has been damaged.
- Do not disassemble the charger.
- To reduce the risk of electrical shock, always unplug the charger from the AC outlet and remove from the Medicare Battery Pack before cleaning.

## Maximizing battery life

Charging the batteries for 6-8 hours will achieve maximum battery capacity.

Battery life will depend on the following factors:

- a) Amount of use between charge cycles (% of battery spent).
- b) The length of time a discharged battery sits before being recharged.
- c) The number of charge/discharge cycles the battery experiences

Sealed lead acid batteries do not contain a "memory"; therefore they react better to more frequent charging.

We suggest placing batteries into a rotation. It is not necessary to discharge the battery until the light on the receiver box blinks. Longer battery life is obtained

by more frequent charging.

Chargers may feel warm to the touch. This is normal. It is caused by energy transferring between the battery and the charger. If charger is excessively warm, troubleshoot battery before checking charger. Please see Troubleshooting Guide on page 22 for more information on battery problems.

Dispose of all unusable batteries in accordance with your state laws, local ordinances and facility policies.

## Checking voltage

To check voltage, set volt meter to DCV 200.

**Charger** – Check left and middle prong for voltage. Meter should read 27.6 volts.

**Battery** – Check right and middle prong for voltage. Meter should read 26-27 volts when battery is fully charged.

NOTE: Sealed lead acid batteries are non-spillable and are NOT considered hazardous materials.

# Care Lift Parts List

- 1 – 400700 Scale Display
- 400710 Scale Display Circuit Board
- 2 – 400990 Hand Control
- 3 – 400092 SKF Actuator Cover\*
- 400338 Linak Actuator Cover\*
- 4 – 400198 Lift Mast
- 400177 600 lb Lift Mast
- 5 – 400902 Receiver Box
- 400963 Receiver Circuit Board
- 400939 Receiver Box Plug (Toggle Switch)
- 4 00936 Circuit Breaker (On/Off Switch)
- 6 – 400901 Battery Pack
- 7 – 401350 Foot Pedal (Hardware Included)
- 401349 F oot Pedal Pin Refurb Kit
- 8 – 400324 Nylock Nut
- 9 – 400315 Rear Wheel (Hardware Included)
- 10 – 400150 Flat Washer
- 11 – 400575 Lock Washer
- 12 – 400569 Linkage Rod Refurb Kit
- 13 – 400499 Lift Leg
- 14 – 400599 Lift Base
- 400170 600 lb Lift Base
- 15 – 400510 Lift Base Cover
- 16 – 400410 Lift Leg Cover
- 17 – 400320 Front Wheel (Hardware Included)
- 400405 Cap Screw for Wheel
- 400325 Nylock Nut
- 18 – 400110 Mast Protector
- 19 – Contact Medicare for Actuator\*
- 20 – 403125 SKF Lift Actuator Bolt Refurb Kit\*
- 403126 Linak Lift Actuator Bolt Refurb Kit\*
- 21 – 400606 Sling Support Bar
- 22 – 400096 Padded Hanger Bar Cover
- 23 – 400093 Padded Yoke Cover
- 24 – 400600 Scale Hanger Assembly
- 400600R Scale Hanger Rebuild (Contact Technical Support)
- 400607 Blank Scale Hanger
- 25 – 400625 Load Cell Housing
- 26 – 400620 Boom Head Cushion
- 27 – 400298 Lift Boom
- 28 – 400299 Boom Support
- 29 – 402950 Boom/Mast Bolt Refurb Kit
- 30 – 400220 Mast Cap

\*Note: If you are not sure which actuator your lift or stand has, contact Medicare Technical Support at 1-800-695-4479

- #400001 Care Lift 475™
- #400019 Care Lift 600™
- #400000 LIBI Lift 475™
- #400003 Care Lift-n-Weigh 475™
- #400013 Care Lift-n-Weigh 600™

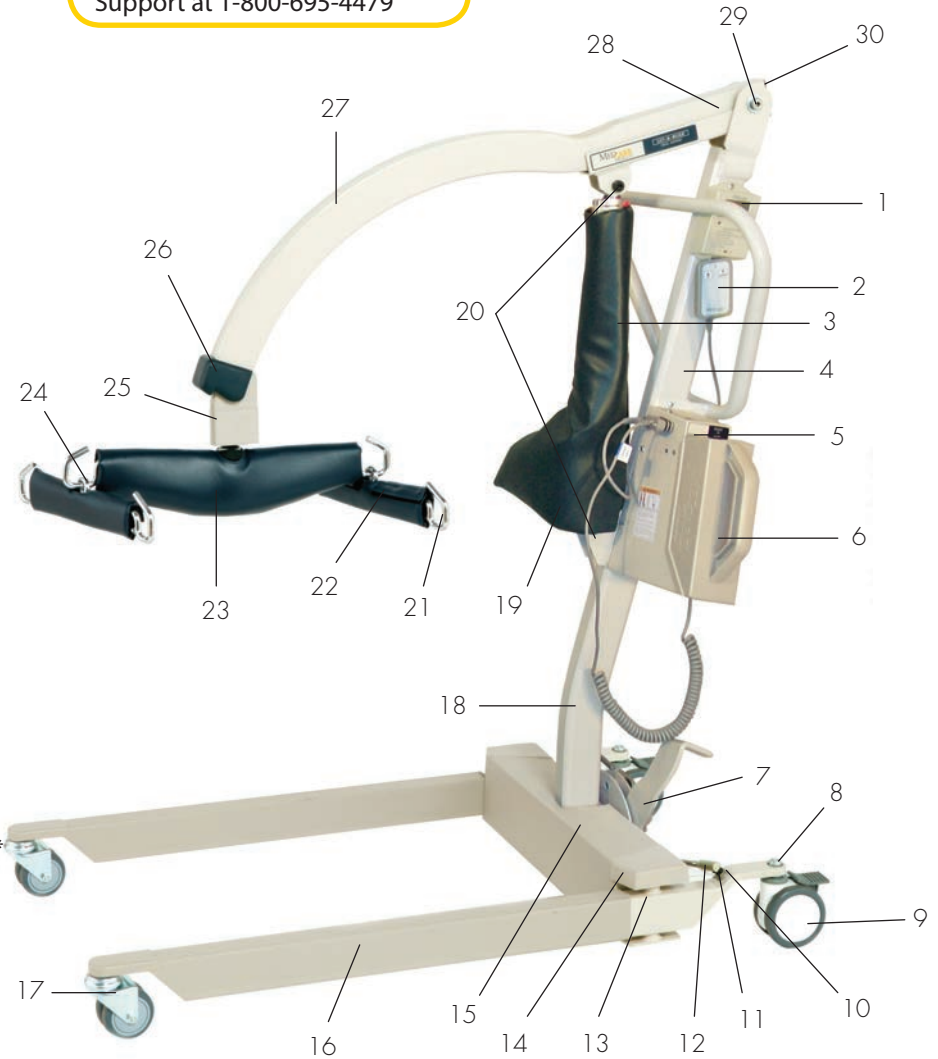

### Items Not Pictured

- 400810 Charger
- 400421 Leg Bolt
- 400565 Nylock Nut for Ball Joints (Used with Pivot Bar)
- 400325 Nylock Nut for Foot Pedal
- 400132 Grommet on Mast
- 400246 Nylon Boom Washer
- 400760 Power Cable for Scale
- 403206 Touch-up Paint Bottle
- 401511 Foam Padding in Base Cover
- 400120 Small Phillips Screw
- 402960 Mast/Base Bolt Refurb Kit
- 403050 Boom/Hanger Bolt Refurb Kit
- 402975 Base/Pivot Bar Refurb Kit
- 400585 Leg Spreader Handle
- 400590 Black Plastic Ball for Handle
- 400497 Torque Retainer Kit (Leg Bolt)
- 400611 Stand Strap Stopper
- 400667 Black Headliner Retainer



# Care Stand Parts List

- 1 – 400700 Scale Display
- 400710 Scale Display Circuit Board
- 2 – 400990 Hand Control
- 3 – 401199 Stand Mast
- 402199 SNW Mast
- 4 – 403000 Stand Arm Pin Refurb Kit
- 5 – 400902 Receiver Box
- 400963 Receiver Circuit Board
- 400939 Receiver Box Plug (Toggle Switch)
- 400936 Circuit Breaker (On/Off Switch)
- 6 – 400901 Battery Pack
- 7 – 400092 SKF Actuator Cover\*
- 400338 Linak Actuator Cover\*
- 8 – 401350 Foot Pedal (Hardware Included)
- 401349 Foot Pedal Pin Refurb Kit
- 9 – 400569 Linkage Rod Refurb Kit
- 10 – 400324 Nylock Nut
- 11 – 400315 Rear Wheel (Hardware Included)
- 12 – 400150 Flat Washer
- 13 – 400575 Lock Washer
- 14 – 401499 Stand Leg
- 15 – 401599 Stand Base
- 402599 SNW Base
- 16 – 401510 Stand Base Cover
- 401515 SNW Base Cover
- 17 – 401410 Stand Leg Cover
- 18 – 400320 Front Wheel (Hardware Included)
- 400405 Cap Screw for Wheel
- 400325 Nylock Nut
- 19 – 401596 Stand Foot Tray
- 402596A SNW Foot Tray
- 20 – 401512 Plastic Foot Tray Cover
- 401513 3 Piece Grip Tape (Foot Tray)
- 21 – Contact Medicare for Actuator\*
- 401300 SKF Stand Actuator Bolt Refurb Kit\*
- 401299 Linak Stand Actuator Bolt Refurb Kit\*
- 22 – 401009 Knee Pad Assembly
- 401010 Knee Pad
- 401011 Black Plastic Knee Pad Backing
- 401126 Knee Pad Mounting Screw
- 401012 Velcro Strap
- 401198 Knee Pad Bracket
- 401175 Plastic Glide
- 23 – 401275 Hand Grips
- 24 – 400097 Padded Arm Cover Set
- 25 – 401298 Stand Arm
- 401297 Stand Arm–500 lbs.
- 400738 Finishing Plug for Square Tube
- 26 – 400220 Mast Cap

\*Note: If you are not sure which actuator your lift or stand has, contact Medicare Technical Support at 1-800-695-4479

- #400005 Care Stand-n-Weigh 350™
- #450006 Care Stand Plus 440™
- #450007 Care Stand-n-Weigh Plus 440™
- #400006 Care Stand 500™
- #400007 Care Stand-n-Weigh 500™

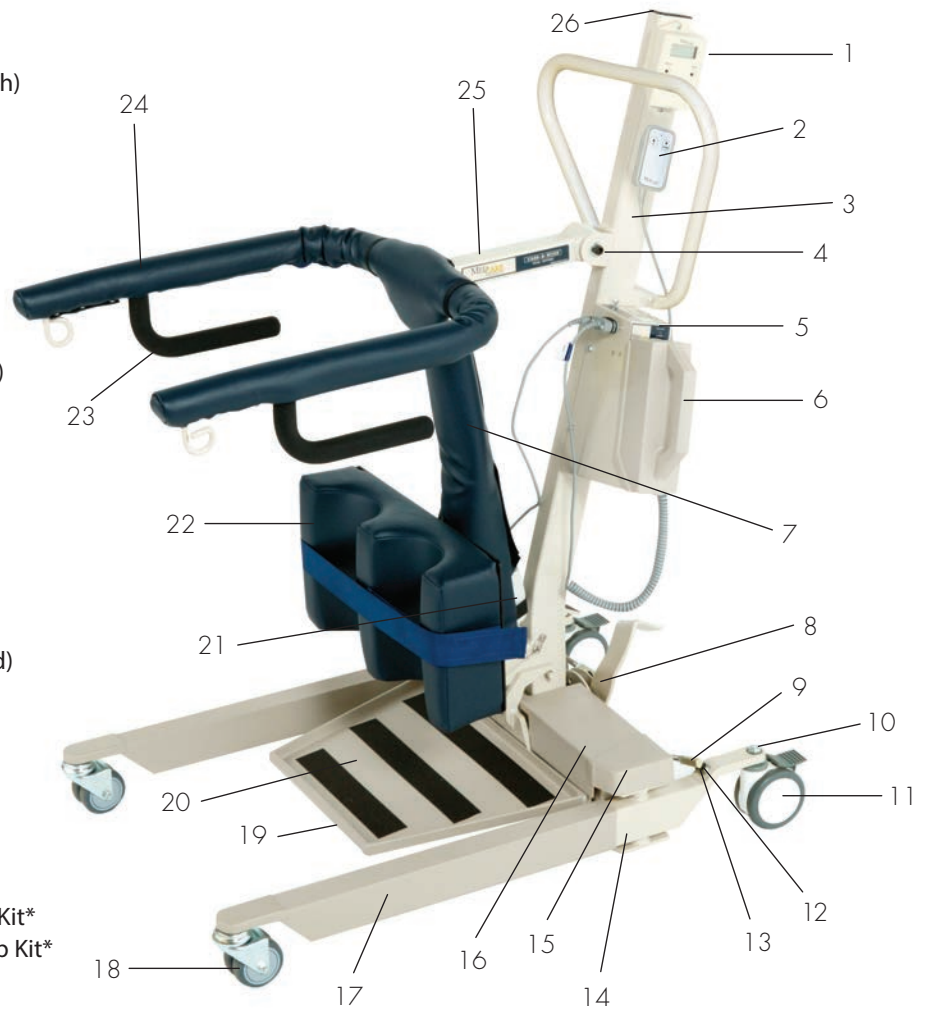

## Items Not Pictured

- 400810 Charger
- 400421 Leg Bolt
- 402001 SNW Base Block
- 400247 Nylon Washer for Arm
- 402596B SNW L-Shape Base Plate
- 401706 Black Stand Arm Cap
- 401699 SNW Load Cell
- 400132 Grommet on Mast
- 401572 Pin with Safety Cable
- 400120 Small Phillips Screw
- 401511 Foam Padding in Base Cover
- 400760 Power Cable for Scale
- 403206 Touch-up Paint Bottle
- 402960 Mast/Base Bolt Refurb Kit
- 403075 SNW Load Cell Bolt Refurb Kit
- 402975 Base/Pivot Bar Refurb Kit
- 400585 Leg Spreader Handle
- 400590 Black Plastic Ball for Handle
- 400497 Torque Retainer Kit (Leg Bolt)
- 401011 Black Cap for Knee Pad Bracket
- 400611 Stand Strap Stopper

# Car Extractor Parts List

#450000 475™

#450045 Low Pro 475™

- 1 – 400990 Hand Control
- 2 – 400092 SKF Actuator Cover\*
- 400338 Linak Actuator Cover\*
- 3 – 450198 Mast
- 4 – 400902 Receiver Box
- 400963 Receiver Circuit Board
- 400939 Receiver Box Plug (Toggle Switch)
- 400936 Circuit Breaker (On/Off Switch)
- 5 – 400901 Battery Pack
- 6 – 401350 Foot Pedal (Hardware Included)
- 401349 Foot Pedal Pin Refurb Kit
- 7 – 400569 Linkage Rod Refurb Kit
- 8 – 400324 Nylock Nut
- 9 – 400315 Rear Wheel (Hardware Included)
- 10 – 400150 Flat Washer
- 11 – 400575 Lock Washer
- 12 – 400499 Lift Leg
- 13 – 400599 Lift Base
- 14 – 400510 Lift Base Cover
- 15 – 400410 Lift Leg Cover
- 16 – 400320 Front Wheel (Hardware Included)
- 400405 Cap Screw for Wheel
- 400325 Nylock Nut
- 400442 Low Pro Wheel w/ Bearing
- 400443 Low Pro Wheel w/o Bearing
- 400441 Low Pro Bearing
- 17 – 400110 Mast Protector
- 18 – Contact Medicare for Actuator\*
- 19 – 403125 SKF Lift Actuator Bolt Refurb Kit\*
- 403126 Linak Lift Actuator Bolt Refurb Kit\*
- 20 – 400093 Padded Yoke Cover
- 21 – 400607 Blank Scale Hanger
- 400133 Blank Scale Hanger Bushings
- 22 – 400620 Boom Head Cushion
- 23 – 400296 Car Extractor Boom
- 24 – 400299 Boom Support
- 25 – 402950 Boom/Mast Bolt Refurb Kit
- 26 – 400220 Mast Cap

\*Note: If you are not sure which actuator your lift or stand has, contact Medicare Technical Support at 1-800-695-4479

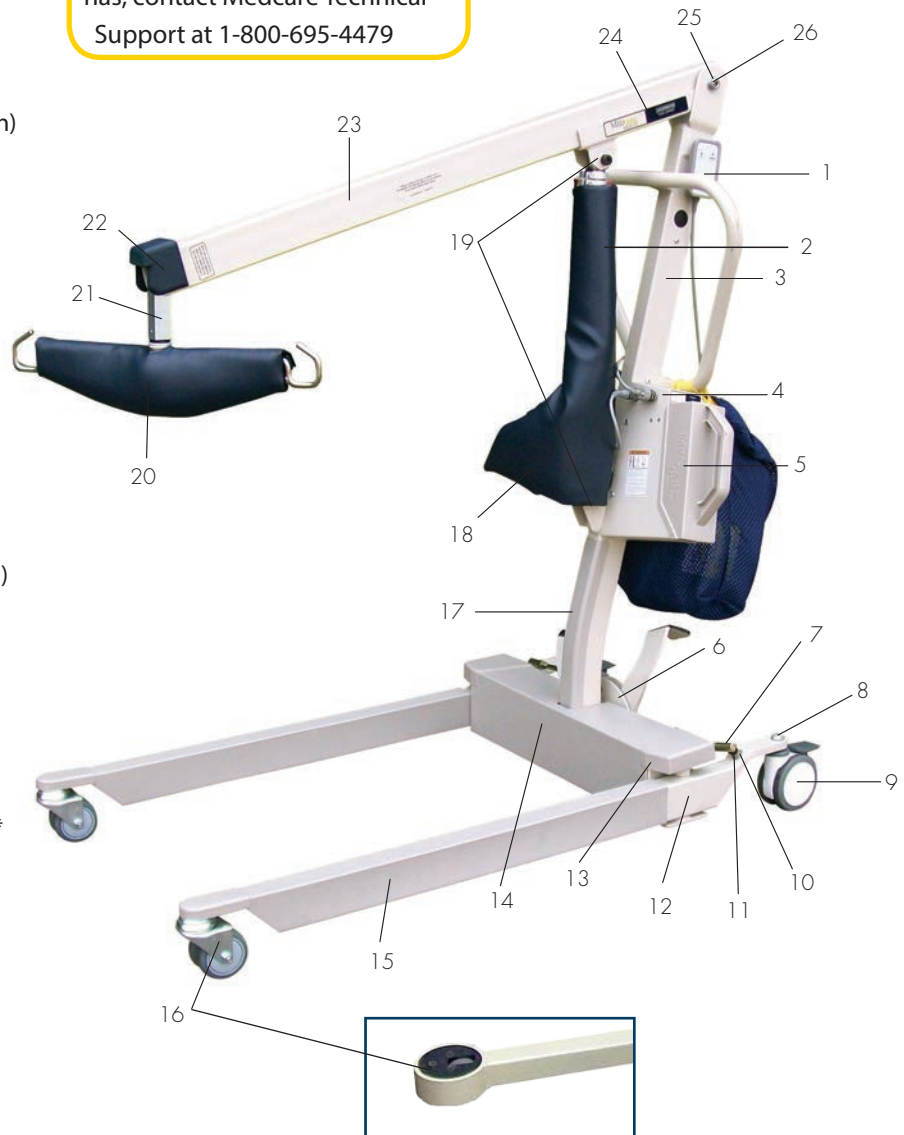

### Items Not Pictured

- 400810 Charger
- 400421 Leg Bolt
- 400565 Nylock Nut for Ball Joints (Used with Pivot Bar)
- 400325 Nylock Nut for Foot Pedal
- 400132 Grommet on Mast
- 400246 Nylon Boom Washer
- 400760 Power Cable for Scale
- 403206 Touch-up Paint Bottle
- 401511 Foam Padding in Base Cover
- 400120 Small Phillips Screw
- 402960 Mast/Base Bolt Refurb Kit
- 403050 Boom/Hanger Bolt Refurb Kit
- 402975 Base/Pivot Bar Refurb Kit
- 400585 Leg Spreader Handle
- 400590 Black Plastic Ball for Handle
- 400497 Torque Retainer Kit (Leg Bolt)
- 400611 Stand Strap Stopper
- 400667 Black Headliner Retainer

# Low Pro Lift Parts List

- 1 – 400700 Scale Display
- 400710 Scale Display Circuit Board
- 2 – 400990 Hand Control
- 3 – 400092 SKF Actuator Cover\*
- 400338 Linak Actuator Cover\*
- 4 – 400198 Lift Mast
- 400177 600 lb Lift Mast
- 5 – 400902 Receiver Box
- 400963 Receiver Circuit Board
- 400939 Receiver Box Plug (Toggle Switch)
- 400936 Circuit Breaker (On/Off Switch)
- 6 – 400901 Battery Pack
- 7 – 401350 Foot Pedal (Hardware Included)
- 401349 Foot Pedal Pin Refurb Kit
- 8 – 400324 Nylock Nut
- 9 – 400315 Rear Wheel (Hardware Included)
- 10 – 400150 Flat Washer
- 11 – 400575 Lock Washer
- 12 – 400569 Linkage Rod Refurb Kit
- 13 – 400431 Low Pro Lift Leg
- 400430 Low Pro Leg Assembly
- 400441 Low Pro Leg Assembly Pair
- 14 – 400599 Lift Base
- 400170 600 lb Lift Base
- 15 – 400510 Lift Base Cover
- 16 – 400442 Low Pro Wheel w/ Bearing
- 400443 Low Pro Wheel w/o Bearing
- 400441 Low Pro Bearing
- 17 – 400110 Mast Protector
- 18 – Contact Medicare for Actuator\*
- 19 – 403125 SKF Lift Actuator Bolt Refurb Kit\*
- 403126 Linak Lift Actuator Bolt Refurb Kit\*
- 20 – 400606 Sling Support Bar
- 21 – 400096 Padded Hanger Bar Cover
- 22 – 400093 Padded Yoke Cover
- 23 – 400600 Scale Hanger Assembly
- 00600R Scale Hanger Rebuild (Contact Technical Support)
- 400607 Blank Scale Hanger
- 24 – 400625 Load Cell Housing
- 25 – 400620 Boom Head Cushion
- 26 – 400298 Lift Boom
- 27 – 400299 Boom Support
- 28 – 400295 Boom/Mast Bolt Refurb Kit
- 29 – 400220 Mast Cap

\*Note: If you are not sure which actuator your lift or stand has, contact Medicare Technical Support at 1-800-695-4479

- #450001 Low Pro 475™
- #450003 Low Pro Lift-n-Weigh 475™
- #450013 Low Pro Lift-n-Weigh 600™
- #450019 Low Pro 600™



## Items Not Pictured

- 400810 Charger
- 400421 Leg Bolt
- 400565 Nylock Nut for Ball Joints (Used with Pivot Bar)
- 400325 Nylock Nut for Foot Pedal
- 400132 Grommet on Mast
- 400220 Mast Cap
- 400246 Nylon Boom Washer
- 400760 Power Cable for Scale
- 403206 Touch-up Paint Bottle
- 401511 Foam Padding in Base Cover
- 400120 Small Phillips Screw
- 402960 Mast/Base Bolt Refurb Kit
- 403050 Boom/Hanger Bolt Refurb Kit
- 400497 Torque Retainer Kit (Leg Bolt)
- 400611 Stand Strap Stopper
- 400667 Black Headliner Retainer

# Care Lift and Stand Accessories

\*\*The following accessories are not included with the purchase of a Care Lift or Stand.

## LiftandStandAccessories

- 1 – 402125 50 lb Certified Weight for Calibration
- 2 – 400903 Charger Wall Mount Bracket
- 3 – 400094 Mesh Bag



Contact your Medicare Safe Patient Handling Consultant for more details about accessories.

## Care Stand Accessories

400611 Stand Strap Stopper



## Care Lift Accessories

400611 Lift Strap Stopper

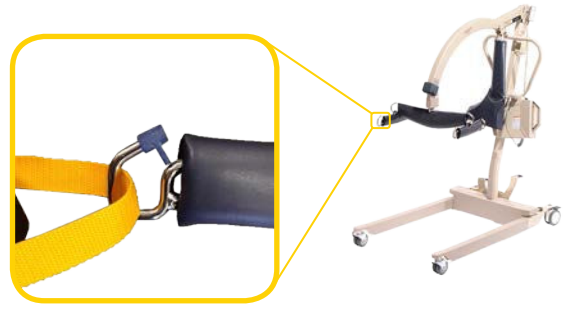

All accessories are sold separately. To order, contact your Medicare Safe Patient Handling Consultant, or Customer Service at 1-800-695-4479.



# Limited Warranty

Medcare Products, Inc. extends the following LIMITED WARRANTY to the original owner of Medcare merchandise that is purchased:

1. LIMITED WARRANTY ON FRAME AND WELDS. If the frame of the product or a weld should crack or break, it will be replaced by Medcare. Warranty term: Five (5) years from the date of sale.
2. LIMITED WARRANTY ON PARTS. If the following parts are defective in material or workmanship, Medcare will supply replacement parts: all bolts, nuts, washers, bearings, bushings, foot pedal assemblies, load cells, scale display circuit boards, battery chargers and battery receiver box circuit boards. Warranty term: Two (2) years from the date of sale.
3. LIMITED WARRANTY ON BATTERIES, HAND CONTROLS AND ACTUATORS. If your batteries, hand controls or actuators are defective, Medcare will replace or repair them, at Medcare's option. Warranty term: One (1) year from the date of sale.
4. LIMITED WARRANTY ON SLINGS AND BELTS. If material is defective and tears or the stitching pulls away from the material on your slings or belts, Medcare will replace them. Warranty term: Six (6) months from the date marked on the tag of the sling. The removal or alteration of the date tag will void this warranty.
5. CONDITIONS AND EXCEPTIONS. a. Any product misuse, abuse or alteration, failure to comply with care, safety or operating instructions, failure to comply with inspection requirements, or any other condition resulting from occurrences beyond the control of Medcare will void this warranty. b. This warranty shall apply only in the United States, its territories or possessions, and Canada.
6. REPLACEMENT AND REPAIR EXPENSES. Medcare will provide only replacement parts under this warranty. The Owner is responsible for all other costs. Such costs may include, but are not limited to: a. labor charges for service, removal, repair or reinstallation of the product or any component part; and b. all necessary or incidental costs related to installation of the replacement parts. Medcare reserves the right to inspect part(s) prior to honoring warranty.
7. CLAIM PROCEDURES: If service on your Medcare product is required during the warranty period, please contact our Technical Service Department at 1-800-695-4479 for instructions regarding returning or replacing parts. Please have available the following information: (i) the date of purchase; (ii) the serial number of your product (located on the mast) and (iii) a description of the nature of the problem.
8. OWNER'S RIGHTS: This Limited Warranty gives you specific legal rights. You may also have other rights, which vary from state to state.
9. LIMITATION OF IMPLIED WARRANTIES. ALL IMPLIED WARRANTIES, EXCEPT TO THE EXTENT PROHIBITED BY APPLICABLE LAW, SHALL HAVE NO GREATER DURATION THAN THE WARRANTY PERIOD SET FORTH ABOVE. THERE ARE NO WARRANTIES THAT EXTEND BEYOND THE DESCRIPTION IN THIS LIMITED WARRANTY. BECAUSE SOME STATES DO NOT ALLOW LIMITATIONS ON HOW LONG AN IMPLIED WARRANTY LASTS, THE ABOVE LIMITATION MAY NOT APPLY TO YOU.
10. DISCLAIMER. NO OTHER EXPRESS WARRANTY HAS BEEN MADE OR WILL BE MADE ON BEHALF OF MEDCARE WITH RESPECT TO ANY MEDCARE PRODUCT OR THE OPERATION, REPAIR OR REPLACEMENT OF ANY MEDCARE PRODUCT. MEDCARE SHALL NOT BE RESPONSIBLE FOR INJURY, LOSS OF USE OF THE PRODUCT, INCONVENIENCE, LOSS OR DAMAGE TO PERSONAL PROPERTY, WHETHER DIRECT OR INDIRECT, AND INCIDENTAL OR CONSEQUENTIAL DAMAGES.

Important Notice: Please note that only replacement parts sold by Medcare Products or its authorized representatives or distributors should be used on lifts and stands manufactured by Medcare Products. The use of any non-authorized replacement parts on equipment manufactured by Medcare voids the warranty of the equipment and shall constitute a waiver of any claim of liability by the user, the patient, the owner and any other bystanders against Medcare Products for injury to person or property in connection with the use of Medcare equipment.

Medcare recommends the use of Medcare branded slings and belts on Medcare lifts. Accordingly, the purchaser hereby accepts full responsibility for inspecting the condition of all slings and belts before each use.

# Troubleshooting Guide

I. Scale		
Problem	Cause	Remedy
1. Inaccurate weights.	1. Not zeroing out scale properly.	1. Zero scale according to directions.
	2. Pounds/Kilograms switch is in the wrong setting.	2. Switch to desired setting.
	3. System is out of calibration.	3. Calibrate unit using a certified 50 lb. weight. Follow instructions for calibration.
	4. Patient/resident is moving while trying to take weight.	4. Make sure that the patient/resident is hanging evenly under the boom cushion and has minimal movement.
2. Display is erratic.	1. Display circuit board is bad.	1. Check using a functioning display on another stand or lift if possible. If it works, order a new scale display circuit board. (Part #400710)
3. Nothing appears on display screen.	1. Power not turned on.	1. Turn on power on battery receiver box. Press the weight button.
	2. Wiring harness connecting battery receiver box to display box has been disconnected.	2a. Remove digital display box and reconnect 2-prong (yellow & black) wiring harness to the display box. 2b. Remove receiver box and make sure (yellow & black) wiring harness is plugged in.
4. Display box zeros out but will not change when pressure is applied to the platform (Stand-N-Weigh) or the hanger (Total Lift with scale).	1. The wiring harness connecting the load cell to the display box has either been cut or disconnected.	1. Remove the display box and reconnect the black 4-prong plug to the display board.
		2. Check entire black wire connecting the load cell to the display box for a cut or break. If cord is cut or pinched, replace scale hanger assembly. (Part #400600)

II. Lift or Stand		
1. Lift will not go up or down.	1. Plug from actuator to battery box is not securely attached.	1. Push plug firmly into socket.
	2. Dead Battery.	2. Charge battery.
	3. Hand control not plugged in completely.	3. Tighten small allen screws holding hand control in. (NOTE: Do not over tighten).
	4. Machine turned off.	4. Turn switch to "ON" on the back of battery receiver housing.
	5. Hand control is broken. (Unplug hand control from machine, try the chrome "UP/DOWN" toggle switch and if it works, you will need to replace the hand control.)	5. Purchase new hand control.
	6. Receiver box circuit board is broken. (Plug actuator into another functioning lift or stand and check if it will raise and lower with both the toggle switch and hand control.)	6. Replace receiver box circuit board.
	7. Battery not pushed into receiver box far enough to make connection.	7. Make sure battery pack is pushed firmly into battery receiver box.
	8. Actuator not working and only clicks.	8. Replace actuator.

III. Actuator		
Problem	Cause	Remedy
1. Actuator makes noise or wobbles.	1. Faulty or worn out actuator.	1. Replace actuator.

IV. Battery Pack		
1. Charge battery light stays on constantly.	1. Batteries are worn out. (Cells are bad.)	1. Order new batteries.
2. Batteries wearing out too quickly.	1. Batteries are not being charged long enough. They need an eight hour charge.	1. Order new batteries. Make sure that you charge batteries after a full day's use. Do not wait for the red light to come on.
3. Battery will not plug into unit far enough to make contact.	1. Receiver box receptacle broken.	1. Order receiver box plug (item # 400939).

V. Battery Charger		
1. Battery charger heats up.	1. Batteries have worn out and are unable to be charged any further.	1. Order new batteries. Also, make sure that you charge batteries after a full day's use or when the red light comes on.
2. Battery charger lights do not come on when plugged in.	1. Electrical outlet is not operational.	1. Use different outlet.
3. Red & green lights blink in rotation.	1. Charger is testing battery.	1. This should go away after a couple of complete discharge and recharge cycles.

VI. Receiver Box		
1. Received box visual and audible warnings.	1. Low battery voltage. Warnings: 23.5 volts — LED 23.2 volts — LED and alarm 22.7 volts — LED and double beep	

# Routine Maintenance Overview

Periodic maintenance is a vital component of keeping your equipment in safe operating condition. A machine that is not properly maintained could create potentially hazardous situations for nursing staff and patients. The following contains information on necessary periodic maintenance.

Use the checklist in combination with the Troubleshooting Guide. It will keep your Care Lifts and Stands in safe working condition and reduce the possibility of potentially dangerous situations. Equipment not passing the maintenance tests indicated below should be removed from service until the test can be passed.

Please call 800-695-4479 or visit our website at [www.MedicareLifts.com](http://www.MedicareLifts.com) with any questions.

## Every Day:

- Inspect slings and belts for wear and tear before every use. Immediately remove any damaged slings and belts from service.
- Check the battery. If the indicator lamp is illuminated red, the battery needs to be charged.
- To keep your Care Lifts, Stands and Car Extractors clean, wipe down with a damp cloth using warm water to which a mild detergent has been added.
- When higher levels of disinfection are required, the use of Accelerated Hydrogen Peroxide or similar products is permitted.

## Periodic Testing:

For normal operation:

- Emergency lowering – See page 14 for instructions on the emergency lowering procedures of the actuator.
- Chassis function – Open and close the chassis legs and check for full range of movement.
- General lift condition – A general visual inspection of the external parts and all functions should be carried out to ensure no adverse damage has occurred. If in any doubt, remove the equipment from use and call the Medicare Technical Service Department.

## Recommended Service Life:

- Medicare stands and lifts have an expected life of 10 years. If your stand or lift is older, please consult your Safe Patient Handling Consultant. The serial number on the equipment indicates month and date of production. Please read “Emergency Lowering of Actuator” on page 14 to learn how to read Medicare’s serial numbers.

NOTE: Apply LITHIUM grease to all smooth surfaces where metal on metal contact occurs. Apply LOCTITE threadlocker (medium strength) to all threads before tightening.

NOTE: Do not use petroleum-based solvents, trichloroethylene or similar products in cleaning the surface of Lifts, Stands or Car Extractors.

## Recommended replacement:

- Actuators are recommended to be replaced after four years of use.
- Support bars on lifts should be replaced when excessive wear is apparent.



# Preventive Maintenance Checklist

## General Maintenance

PASS FAIL

- Actuator and Connections** – Check the operation of the actuator. Remove bolts and check for lithium grease. If none present, apply and re-insert. Use of a thread locker is recommended when re-attaching nut to bolt.
- Actuator** – Check the up and down movement. If you hear abnormal noise, contact Medcare's technical support.
- Boom/Arm Pivot Pins & Bushings** – Check the area where the arm or boom meets the mast. Be sure the nut and bolt are securely attached. If not operating smoothly, remove bolt and apply lithium grease. Re-insert the bolt; apply thread locker, and secure nut.
- Scale Display** – Check that scale display works properly.
- Front Casters** – Clean debris from casters and test for smooth rolling.
- Hand Control** – Check that buttons work properly.
- Leg Bolts** – Remove base cover and check to make sure bolts are flush with base. If not, tighten. Periodically remove bolts, apply lithium grease, and re-insert using thread locker on the threads.
- Foot Pedal** – Check that foot pedals work properly.
- Leg Spreader Pivot Bar** – Check the bolt on the base and make sure the nut is at least 2 threads inside the end. This nut may be adjusted to your preferred tension.
- Mast/Base Bolts** – Check bolts to make sure that they are tight. If not, remove, apply thread locker and re-tighten.
- Rear Casters** – Clean and remove debris. Check to make sure the brakes are working properly and that the wheels are firmly attached.
- Receiver Box** – Clean and check for operation. Check that the on/off switch is functioning properly. Try out the toggle switch, and verify both the up and down motion of the actuator.
- Batteries** – Check for damage, and check voltage. Always check voltage of a fully charged battery.
- Charger** – Check for damage to plug, and check voltage.
- Slings & Belts** – Inspect slings and belts for wear and tear before every use. Immediately remove any damaged slings and belts from service and replace.
- Age of Lift or Stand** – Medcare stands and lifts have an expected life of 10 years. If your stand or lift is older, please speak with your Safe Patient Handling Consultant.

## Stand Maintenance

PASS FAIL

- Foot Platform** – Remove the platform and clean. Be sure to remove the plastic footplate cover and clean underneath. Pay particular attention to the plastic and check for sharp edges.
- Knee Pad Assembly** – Check for tears and clean the leg strap and surface of pad.
- Padded Hand Grips** – Clean hand grips, and check that they are pushed all the way on.
- Arm Pads** – Clean and check for wear & tear.

## Lift Maintenance

PASS FAIL

- Emergency Lower** – See page 14 for emergency lowering instructions.
- Hanger Bars** – Check that there are two hanger bars and no significant wear exists.
- Scale Hanger Assembly** – Verify the presence of a cotter pin or castle nut and spring pin.

Additional Checklists and Maintenance Record Sheets are available at [www.MedcareLifts.com](http://www.MedcareLifts.com)

## Parts Guarantee

Medcare guarantees that all essential operating parts will be in stock and shipped within 24 hours from when an order is placed or the part is free.\*

Essential Operating Parts include:

- Actuators
- Batteries
- Receiver Boxes and Chargers
- Casters

\*Customers pay for the cost of shipping on parts not covered under warranty. Unless otherwise noted on the purchase order, parts will be shipped UPS Ground. Customers pay for any expedited shipping on parts covered under warranty.

# Order Form

## Bill To:

Name

---

Mailing Address

---

City State Zip

---

Contact Person

---

PO#

---

Sales Rep

---

## Ship To:

Name

---

Street Address

---

City State Zip

---

Phone

---

Fax

---

E-mail address

---

Qty	Item #	Description
Slings, Belts and Accessories		
	400008	Small Care Sling-Mesh
	400010	Medium Care Sling-Mesh
	400011	Extra Large Care Sling-Mesh
	400012	Large Care Sling-Mesh
	400014	Bariatric Care Sling-Mesh, Antimicrobial
	400015	Bariatric Care Sling
	400017	Extra Large Care Sling
	400018	Small Care Sling
	400020	Medium Care Sling
	400022	Large Care Sling
	400024	Small Multi-Purpose Sling
	400025	Medium Multi-Purpose Sling
	400026	Large Multi-Purpose Sling
	400027	Extra Large Multi-Purpose Sling
	400028	Small Care Sling w/Head Support
	400030	Medium Care Sling w/Head Support
	400032	Large Care Sling w/Head Support
	400034	Extra Large Care Sling w/Head Support
	400036	Bariatric Care Sling w/Head Support, Ant
	400038	Small Care Sling w/Head Support-Mesh
	400040	Medium Care Sling w/HS-Mesh
	400041	Bariatric Care Sling w/HS-Mesh, Antimicr
	400042	Large Care Sling w/HS-Mesh
	400043	Extra Large Care Sling w/HS-Mesh
	400044	Small Multi-Purpose Sling-Mesh

Qty	Item #	Description
Slings, Belts and Accessories		
	400046	Medium Multi-Purpose Sling-Mesh
	400047	XL Multi-Purpose Sling, Mesh
	400048	Large Multi-Purpose Sling-Mesh
	400068	Medsheet Set of Two Sheets
	400071	Small Commode Sling
	400072	Medium Commode Sling
	400073	Large Commode Sling
	400074	Extra Large Commode Sling
	400077	Small Transport Attachment
	400078	Small Deluxe Medicare Stand Belt
	400079	XL Deluxe Transport Attachment
	400080	Medium Deluxe Stand Belt
	400081	Medium Deluxe Transport Attachment
	400082	Large Deluxe Stand Belt
	400083	Large Deluxe Transport Attachment
	400084	XL Deluxe Stand Belt
	400085	Medium Deluxe Belt w/Sheepskin Cover
	400086	Large Deluxe Belt w/Sheepskin Cover
	400090	Medium Transport Combo
	400091	Large Transport Combo
	400250	Limb Sling, 6"
	400275	Limb Sling, 12"
	402450	Stretcher Sling
	402500	Repositioning Sling, Antimicrobial Mesh

Qty	Item #	Description
<b>Disposable Slings &amp; Belts</b>		
	600015	Bariatric Disposable Sling
	600017	XL Disposable Sling
	600018	Small Disposable Sling
	600020	Medium Disposable Sling
	600022	Large Disposable Sling
	600028	Small Disposable Sling w/HS
	600030	Medium Disposable Sling w/HS
	600032	Large Disposable Sling w/HS
	600034	XL Disposable Sling w/HS
	600036	Bariatric Disposable Sling w/HS
	600071	Small Disposable Commode Sling
	600072	Medium Disposable Commode Sling
	600073	Large Disposable Commode Sling
	600074	XL Disposable Commode Sling
	600080	Medium Disposable Belt
	600082	Large Disposable Belt
	600084	XL Disposable Belt
	600200	Disposable Stretcher Sling
	600210	Disposable Repositioning Sling
	600250	Disposable 6" Limb Sling
	600275	Disposable 12" Limb Sling

Qty	Item #	Description
<b>Parts for Lifts &amp; Stands</b>		
	400600	Scale Hanger Assembly
	400607	Blank Scale Hanger Assembly
	400700	Scale Display Assembly
	400710	Scale Display Circuit Board
	400810	Charger
	400901	Battery, New Style
	400902	Receiver Box
	400963	Receiver Circuit Board
	400990	Hand Control
	401349	Foot Pedal Pin Refurb Kit
	401350	Foot Pedal Assembly
<b>Stand &amp; Stand-n-Weigh™ (SNW) Refurb Kits</b>		
	401299	Linak Stand Actuator Bolt Refurb Kit
	401300	SKF Stand Actuator Bolt Refurb Kit
	402825	Plastics Kit for Stand
	402850	Plastics Kit for Stand-n-Weigh (SNW)
	402900	Full Refurb Kit for Stand
	402925	Full Refurb Kit for Stand-n-Weigh (SNW)
	402960	Mast/Base Bolt Refurb Kit
	402975	Base/Pivot Bar Refurb Kit
	403000	Stand Arm Pin Refurb Kit
	400569	Linkage Rod Refurb Kit
	403075	SNW Load Cell Bolt Refurb Kit
<b>Lift &amp; Lift-n-Weigh™ (LNW) Refurb Kits</b>		
	402800	Plastics Kit for Lift
	402875	Full Refurb Kit for Lifts
	402950	Boom/Mast Bolt Refurb Kit
	402960	Mast/Base Bolt Refurb Kit
	402975	Base/Pivot Bar Refurb Kit
	400569	Linkage Rod Refurb Kit
	403050	Boom/Hanger Bolt Refurb Kit
	403125	SKF Lift Actuator Bolt Refurb Kit
	403126	Linak Lift Actuator Bolt Refurb Kit

To place an order for any of these products,  
or for additional questions:  
Contact your Safe Patient Handling Consultant  
  
Call Customer Service at 1-800-695-4479  
  
Fax an order to 1-952-300-2100  
  
Email an order to [medcare@medcarelifts.com](mailto:medcare@medcarelifts.com)



151 East Cliff Road, Suite 10  
Burnsville, MN 55337

Toll-free: 800-695-4479

[www.MedcareLifts.com](http://www.MedcareLifts.com)

© 2016 Medcare Products Inc. Specifications are subject to change without notice.  
All products referred herein are registered trademarks or trademarks of their respective holders.

Manufactured by Prism Medical Ltd.

Rev. 10/6/16